



YouTube



Facebook



LinkedIn

CHEN HSONG

CH 2025.07

Add.: Unit 2001, 20th Floor, Citicorp
Centre, 18 Whitfield Road,
Hong Kong

Tel: 400 930 0026
(0755) 8413 9999

Web: www.chensong.com

TP-SMART

Servo-Driven Two-Platen Injection Molding Machine

550 - 1700T

SINCE

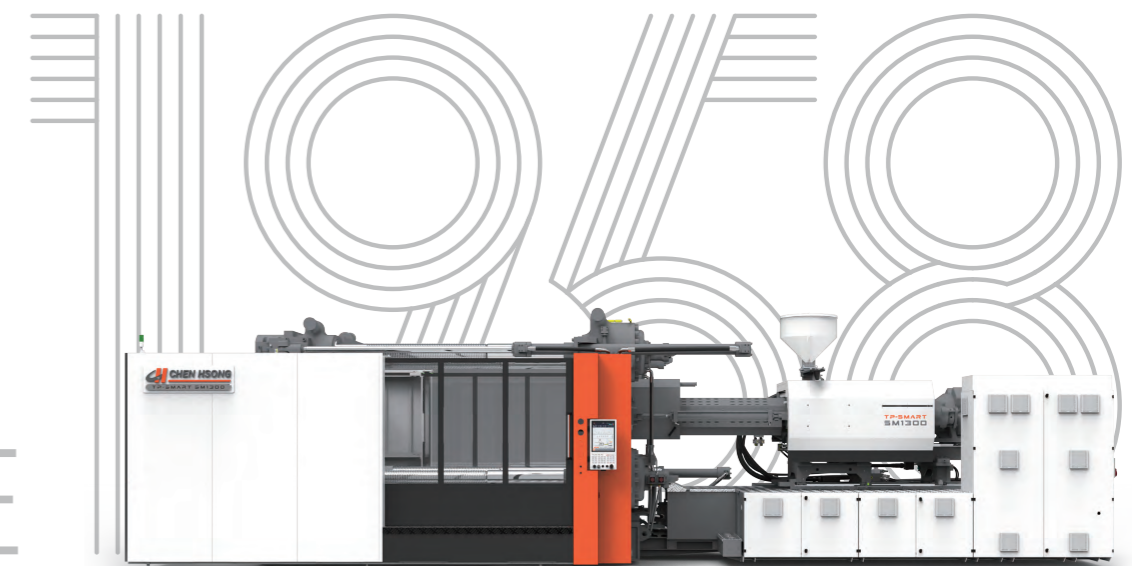

CHEN HSONG

Powering Your Future in Intelligent Injection Molding

Driven by its founding principle, "Your Vision is Our Mission", the Chen Hsong Group, established in 1958 and publicly listed in Hong Kong since 1991, has evolved over nearly 70 years from an injection molding machine manufacturer into a one-stop total solutions provider in plastics manufacturing. As one of the world's largest producers of injection molding machines, Chen Hsong achieves unmatched quality through complete in-house manufacturing. This vertically integrated approach means controlling everything from ductile iron castings, parts fabrication and core components (such as advanced controllers) to final assembly. With a comprehensive product matrix serving diverse industries like automotive and medical, we are also spearheading smart manufacturing upgrades through the iChen™ Smart Family Suite, including the iChen™ Smart Factory MES, iChen™ Cloud platform, and iChen™ AI Molder, making the path to Industry 4.0 easily accessible for our global clientele.

800,000m²

R&D and Production Facilities (Four locations)

85+

Countries Globally

1,000,000+

Injection Molding Machines in the Field

120+

Global Technical & Service Centres



Headquarters in Hong Kong



Shenzhen Industrial Park Factory **560000m²**



Taiwan Taoyuan Factory **30000m²**



Foshan Shunde - Two Factories **150000m²**



Zhejiang Ningbo Factory **70000m²**



Shanwei Luhe Factory **62360m²**

Over 1 million+ Chen Hsong machines are in operation worldwide.

They all use Chen Hsong.



TP-SMART

Two-Platen Injection Molding Machine

Smarter, Stronger, Better..
The TP-SMART has evolved to be smarter beyond your expectations.



* Photos are for reference only.

TP-SMART (W)

Wide Platen Injection Molding Machine

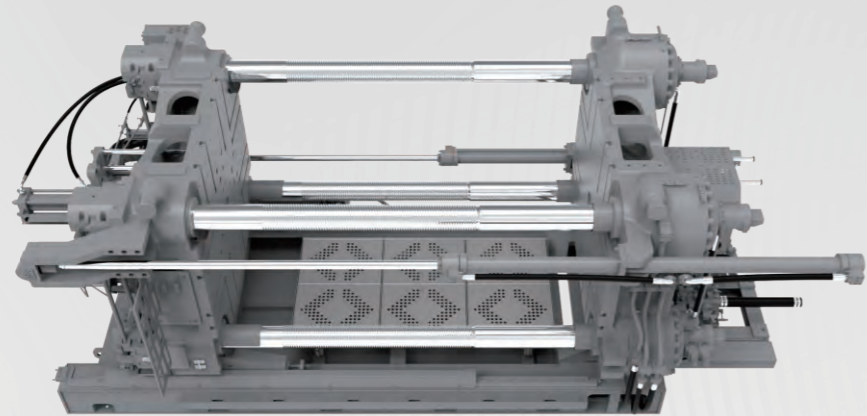

TP-SMART WP wide-platen series

Wider platen dimensions for larger tiebar distances.

Larger daylight and longer opening stroke provide additional capacity for larger, more complex molds.

Enhanced dynamic stability

Facilitates production of deep-cavity parts.
Easily handle molds with complex coring mechanisms.

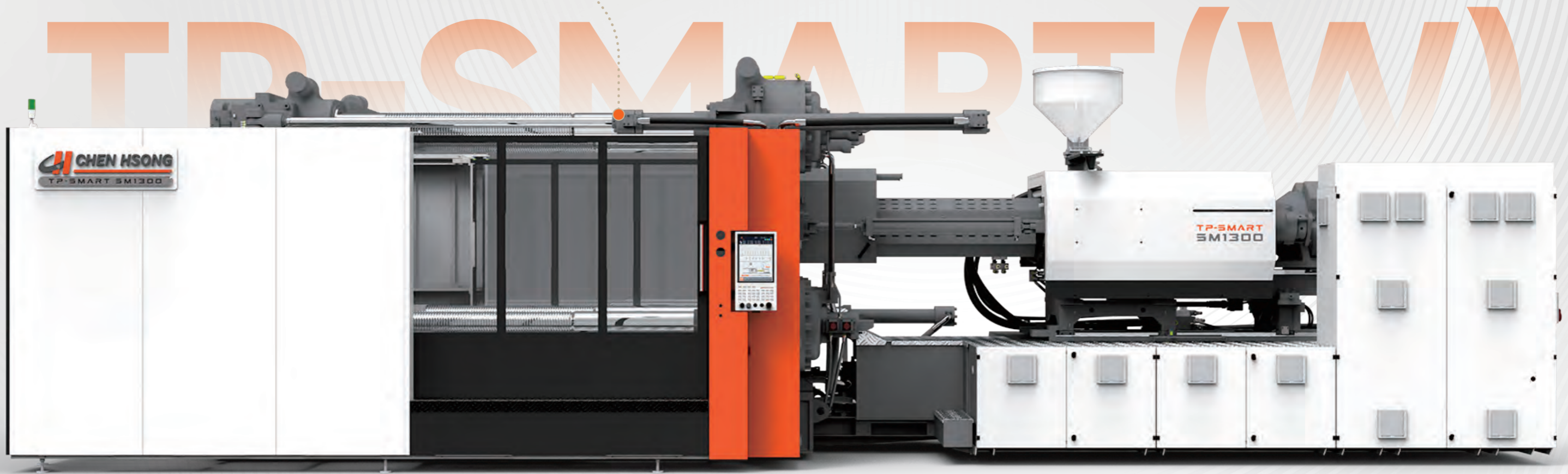

* The product is a demonstration picture, please refer to the actual customisation.

TP-SMART Smart Performance

Cutting-edge

State-of-the-art two-platen technology from Mitsubishi cooperation

Modern

Pleasing on the eyes and the wallet

Ergonomic

User-friendly, easy to operate

Ultra Precise

Designed for high quality parts

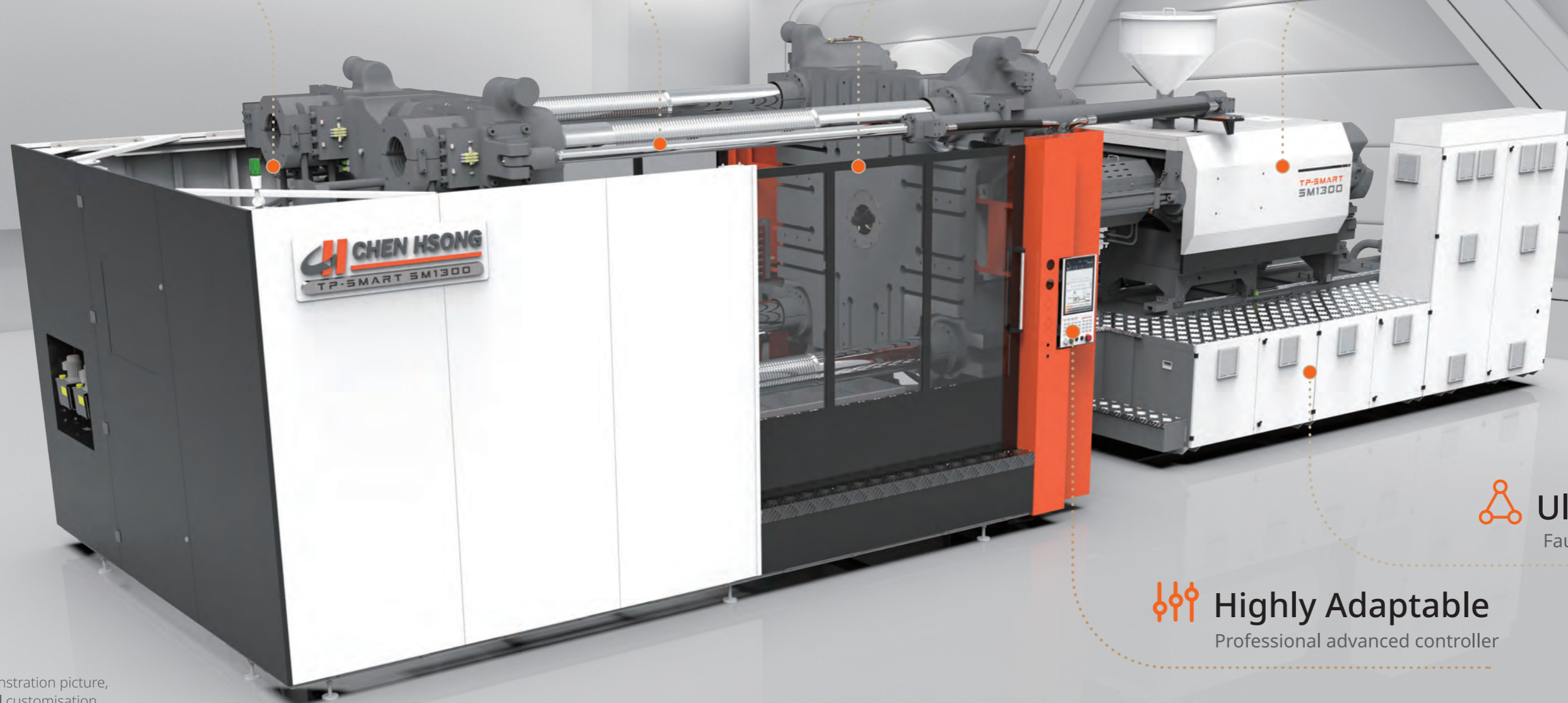

Ultra Stable

Fault-tolerant design

Highly Adaptable

Professional advanced controller

* The product is a demonstration picture, please refer to the actual customisation.

Smart Designs

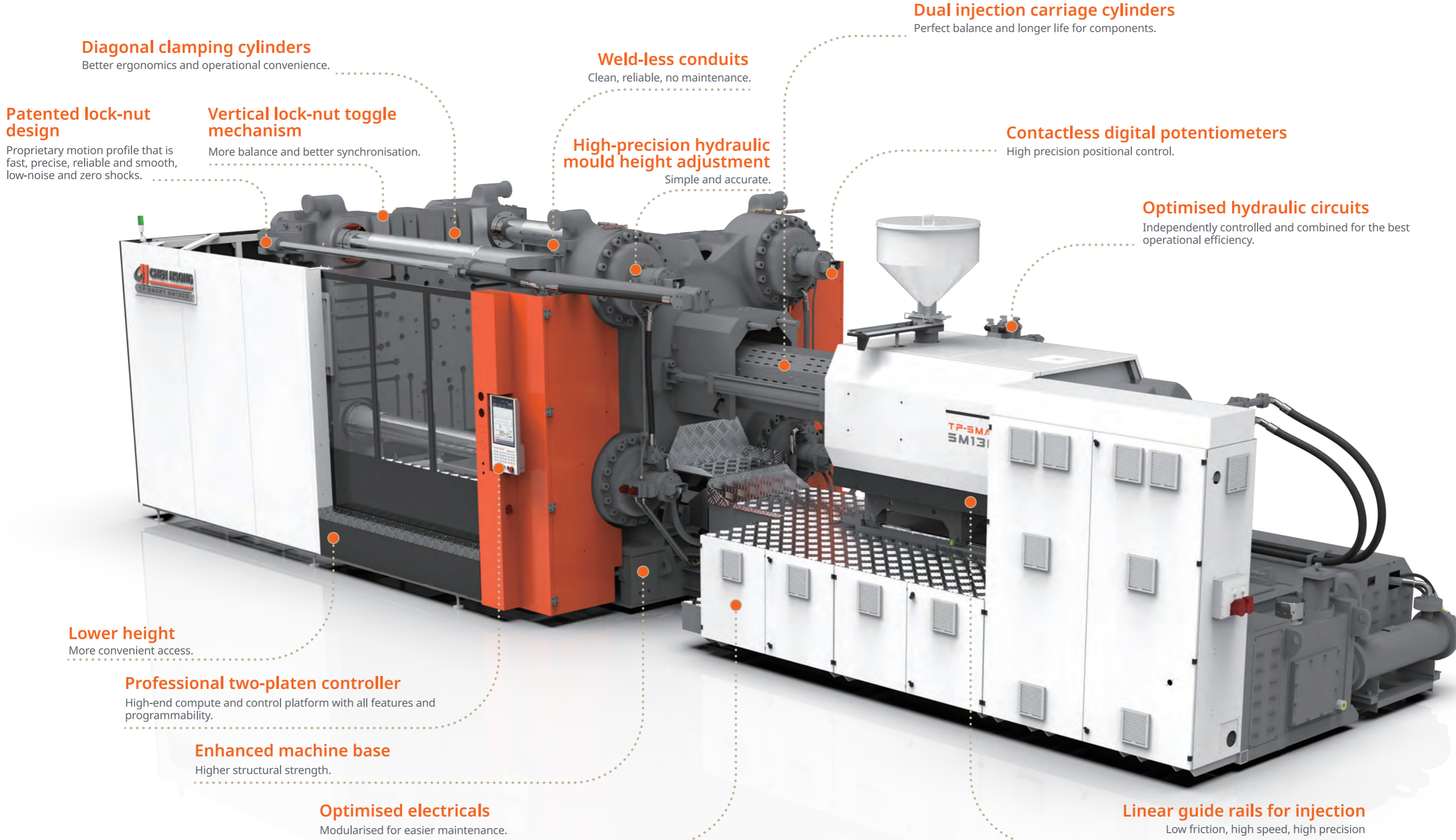

Diagonal clamping cylinders

Better ergonomics and operational convenience.

Patented lock-nut design

Proprietary motion profile that is fast, precise, reliable and smooth, low-noise and zero shocks.

Vertical lock-nut toggle mechanism

More balance and better synchronisation.

Weld-less conduits

Clean, reliable, no maintenance.

High-precision hydraulic mould height adjustment

Simple and accurate.

Dual injection carriage cylinders

Perfect balance and longer life for components.

Contactless digital potentiometers

High precision positional control.

Optimised hydraulic circuits

Independently controlled and combined for the best operational efficiency.

Lower height

More convenient access.

Professional two-platen controller

High-end compute and control platform with all features and programmability.

Enhanced machine base

Higher structural strength.

Optimised electricals

Modularised for easier maintenance.

Linear guide rails for injection

Low friction, high speed, high precision

* Photos are for reference only.

Smart Technologies Cutting-Edge Two-Platen Technology from Mitsubishi Cooperation

Japanese Design

Advanced two-platen design provides the largest stroke and daylight into the smallest foot print possible.

Chen Hsong and Mitsubishi joined forces in a global partnership to create state-of-the-art two-platen technology with unprecedented value proposition.

NON-STOP™

Annual Down-Time as Low as 0.5%!

PRECISION HYDRAULIC™

A team of Japanese and European technical experts took the time-tested hydraulic circuits in our machinery and relentlessly fine-tuned/optimised them to perfection, aided by the latest fluid dynamics simulation software.

Electric plasticising (optional)

Servo electric plasticising is more energy-efficient, with total efficiency of 90% compared to the traditional hydraulic motor.

Servo electric plasticising meets the higher production demands of the automotive industry by utilising synchronous movements.



Equipped with servo electric plasticising for quieter operation.



4th Gen Servo Drive System

Reduced impact, protecting mold and machine

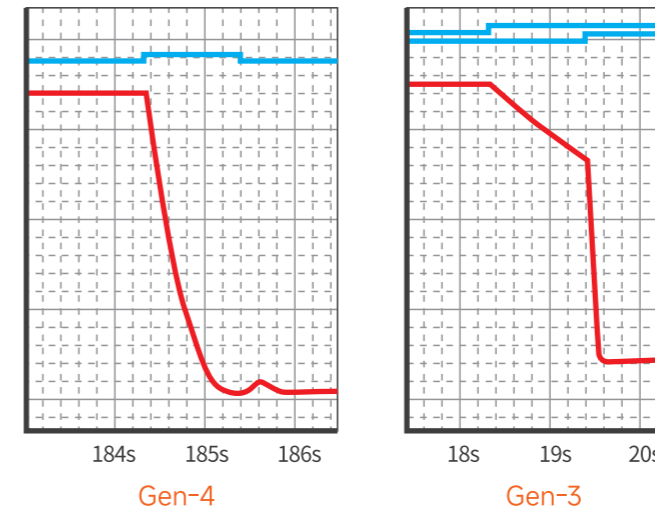

High pressure release speed

2X

High pressure duration (max.)

2X

Mold opening position

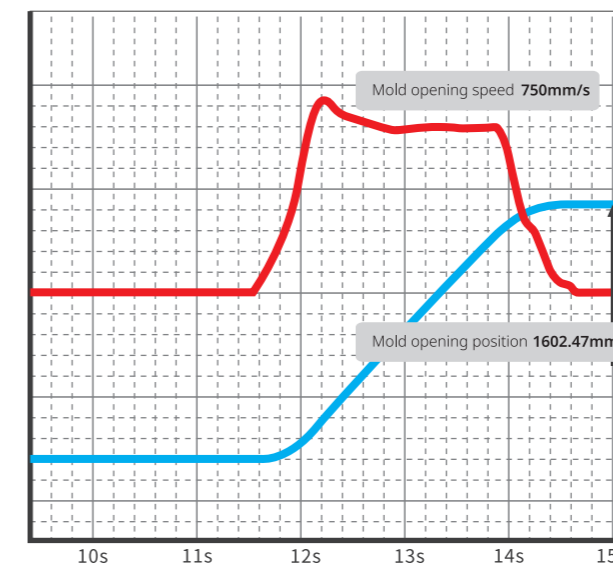

Clamp open position precision

+60%

*Depending on the product and production cycle.

Number of times	1	2	3	4	5	6	7	8	9	10	Average value
Position	1602.6	1602.6	1602.6	1602.6	1602.1	1602.6	1602.5	1602.1	1602.4	1602.6	1602.47

Smart Control

High-end professional computer controller

A perfect match between advanced software, optimised hydraulics and superb hardware design.



15" touch-screen HMI

Smart

Packed full of intelligent automation features.

Fast

204MHz CPU clock enables <200uS closed-loop response.

Fluid

512MB DDR3 RAM and 8GB EMMC Flash memory provide ample system resources for smooth operation and data storage.

Strong

High-performance Cortex-M4 CPU.

Reliable

Modularised power supply channels for electrical stability.

Easy

All-digital controls for easy settings.

Safe

Isolated I/O's for additional fault tolerance.

Precise

Digital main bus with unlimited expandability.

Efficient

User-friendly, simple-to-use HMI with little training required.

* Photos are for reference only.

Standard features

Injection Unit

- | | | |
|--|---------------------------------------|------------------------------|
| 1. 10-stage injection speed/pressure | 2. Digital back pressure control | 3. Nozzle guard |
| 4. Central lubrication points | 5. Barrel guards | 6. Screw RPM display |
| 7. Linear transducer for injection | 8. Ceramic heater bands | 9. Nitrided screw and barrel |
| 10. Linear guide rails on the injection unit | 11. Dual injection carriage cylinders | |

Clamping Unit

- | | | |
|--|--|--|
| 1. Automatic mold thickness adjustment | 2. High-tensile steel tie-bars | 3. Proprietary moving platen slider mechanism |
| 4. High-end ductile casted platens | 5. Motorised guard doors | 6. Contactless potentiometers for positional control |
| 7. High-end potentiometers for ejector control | 8. T-slots | 9. Safety platform (550/750 optional) |
| 10. Water manifold (D12, 8 channels each on moving and stationary platens) | 11. Hydraulic core pulls on moving platen (2 sets) | 12. Multi-stage clamping speed and pressure control |
| 13. Standard-conforming hydraulic/electrical safety interlocks | 14. Advanced low-pressure mold protection | 15. Euromap 13 ejector/core pull interface |

Controller

- | | | |
|---|---|------------------------------------|
| 1. 15" intelligent panel | 2. Rapid-response servosystem | 3. PID temperature control |
| 4. Tri-color status indicator | 5. Real-time monitoring | 6. I/O signals monitor |
| 7. PLC step monitor | 8. Broken thermocouple detection | 9. Cold-start prevention |
| 10. Blocked nozzle and leakage detection | 11. Auto-purge | 12. Robot interface (non-Euromap) |
| 13. Emergency stop switches on both guard doors | 14. Pre-wired core-pull slot on moving platen | 15. 380V/32A power supply (2 sets) |
| 16. 220V/16A power outlet (1 sets) | | |

Hydraulic System

- | | | |
|---|---|------------------------------|
| 1. Internal gear pump | 2. Proportional valve for clamping | 3. Clamping force transducer |
| 4. Boost-mode fast clamp open | 5. Hydraulic oil level indicator | 6. Internal inlet oil filter |
| 7. Multiple sets of hydraulics are independently controlled and combined for optimal output requirements and power efficiency | 8. Core pulls on moving platen (2 sets) | |
| 9. External return oil filter | | |

Optional features

- | | |
|--|---|
| 1. Flexible specialised screw designs | 2. Professional screw & barrel designs (e.g. for PC/ABS/PVC) |
| 3. Automatic lubrication system for injection unit | 4. Longer nozzle (50/100/150/200mm) |
| 5. Cooling ring with temperature control | 6. eDrive – servo-driven recovery |
| 7. Loading platform | 8. Hydraulic oil temperature control |
| 9. Additional power sockets (4/6/8 sets) | 10. Core-pull-on-fly/ejector-on-fly |
| 11. Hot-runner control (8/16/24/32/40/48 channels) | 12. Enlarged cooler |
| 13. Hydraulic sequential device (4/10/12/16 sets) | 14. Additional core pulls on moving platen (3/4 sets) |
| 15. Water manifold (8/16 channels) | 16. Closed-loop injection |
| 17. Bimetallic screw & barrel | 18. CE13 Additional core pull interface on moving platen (Euromap 13) |
| 19. Hydraulic oil pre-heat | 20. Enlarged hydraulic motor |
| 21. Core pulls on stationary platen (1/2/3/4 sets) | 22. E67/E12 E67/E12 interface |
| 23. Hopper slider | 24. Hopper |

SM550TP-SMART

Clamping Unit

Clamping Force	ton	550
Opening Stroke	mm	750-1300
Space Between Tie Bars (H x V)	mm	920x830
Mold Thickness (Min-Max)	mm	350-900
Max. Daylight	mm	1650
Ejection Force	ton	11
Ejection Stroke	mm	250
Mold Register Hole	mm	160

3100 4050

Injection Unit

		A	B	C	A	B	C
Screw Diameter	mm	67	75	83	75	83	90
Screw L/D Ratio	L/D	23.5	21	19	23.2	21	19.4
Screw Stroke	mm		375			415	
Swept Volume	cm ³	1321	1655	2027	1832	2244	2638
Shot Weight (PS)	g	1201	1506	1845	1667	2042	2401
	oz	42.4	53.2	65.1	58.8	72	84.7
Maximum Injection Pressure	kgf/cm ²	2230	1780	1453	2165	1768	1504
Injection Speed	cm ³ /s	379	475	582	431	528	621
Screw Rotation Speed (Max.)	rpm		186			180	

Electrical/Heating

System Pressure	kgf/cm ²	175	175
Servo Pump Motor Power	kW	67	72
Heating Capacity	kW	42	48
Temperature Control Zone		6	6

Other

Machine Dimensions (Length x Width x Height)	m	7.5x2.4x2.4	8x2.4x2.4
Oil Tank Capacity	L	580	600

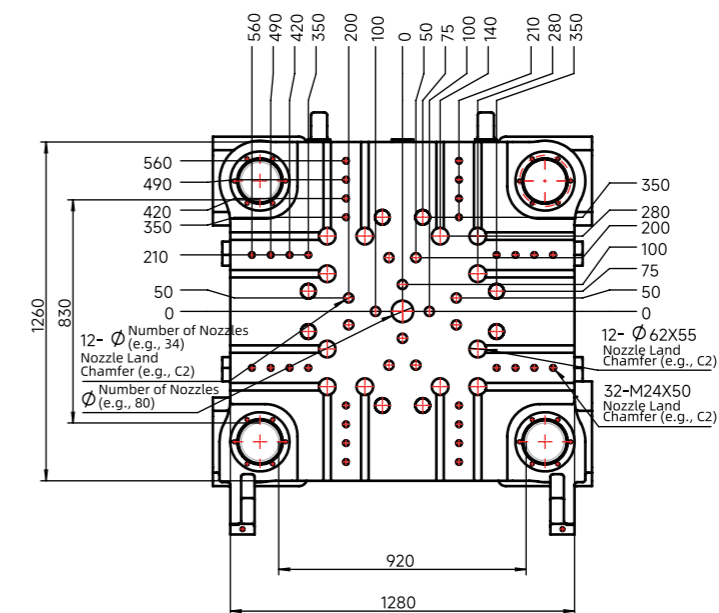
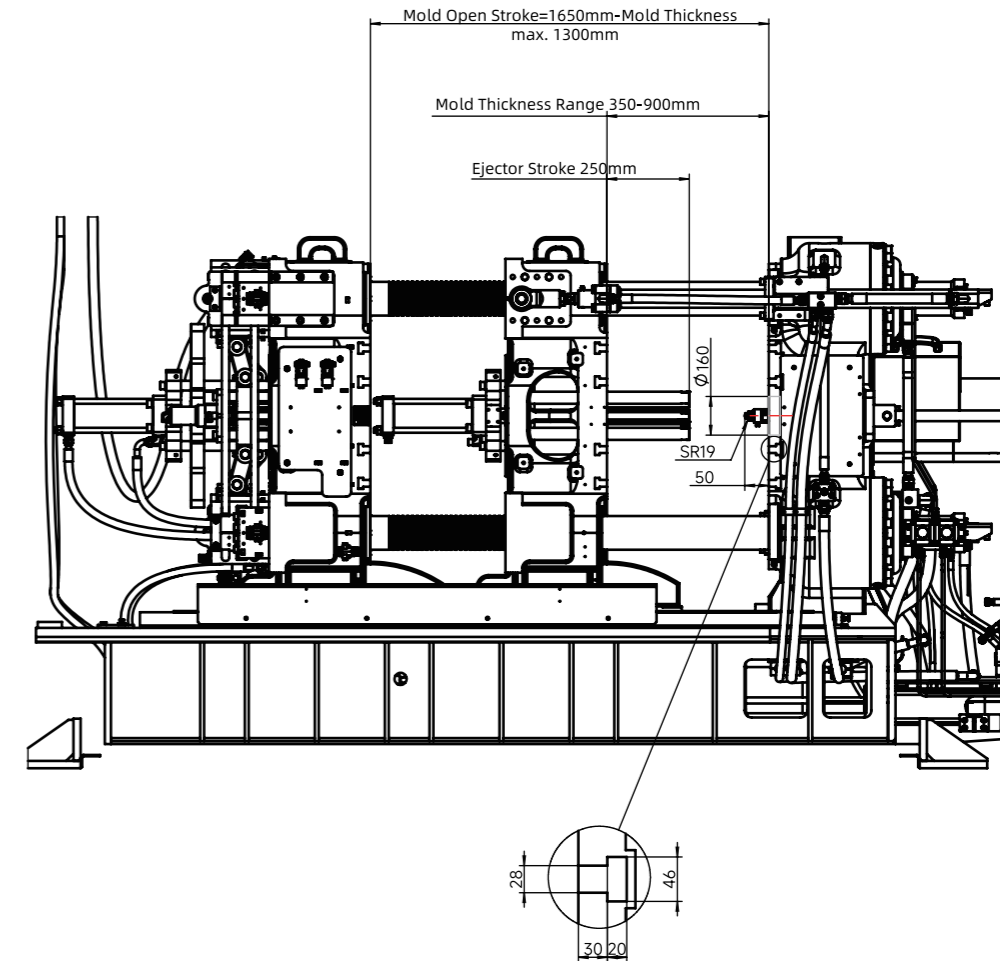

* PS Density (assumed 0.91 g/cm³)

* Note: The oil tank capacity refers to the tank itself and does not include the volume within cylinders and piping. We recommend customers prepare 1.3 times the stated capacity of hydraulic oil. Specifications are subject to change without notice due to continuous technical improvements.

SM1300TP-SMART

Clamping Unit

Clamping Force	ton	1300
Opening Stroke	mm	1450-2300
Space Between Tie Bars (H x V)	mm	1380x1280
Mold Thickness (Min-Max)	mm	500-1350
Max. Daylight	mm	2800
Ejection Force	ton	22
Ejection Stroke	mm	400
Mold Register Hole	mm	200

		9600		
Injection Unit		A	B	C
Screw Diameter	mm	98	110	120
Screw L/D Ratio	L/D	24.7	22	20.2
Screw Stroke	mm	550		
Swept Volume	cm ³	4146	5224	6217
Shot Weight (PS)	g	3773	4754	5658
	oz	133.1	167.7	199.6
Maximum Injection Pressure	kgf/cm ²	2315	1838	1544
Injection Speed	cm ³ /s	731	921	1096
Screw Rotation Speed (Max.)	rpm	116		

Electrical/Heating

System Pressure	kgf/cm ²	175
Servo Pump Motor Power	kW	117
Heating Capacity	kW	60
Temperature Control Zone		7

Other

Machine Dimensions (Length x Width x Height)	m	11.2x3.5x3
Oil Tank Capacity	L	1250

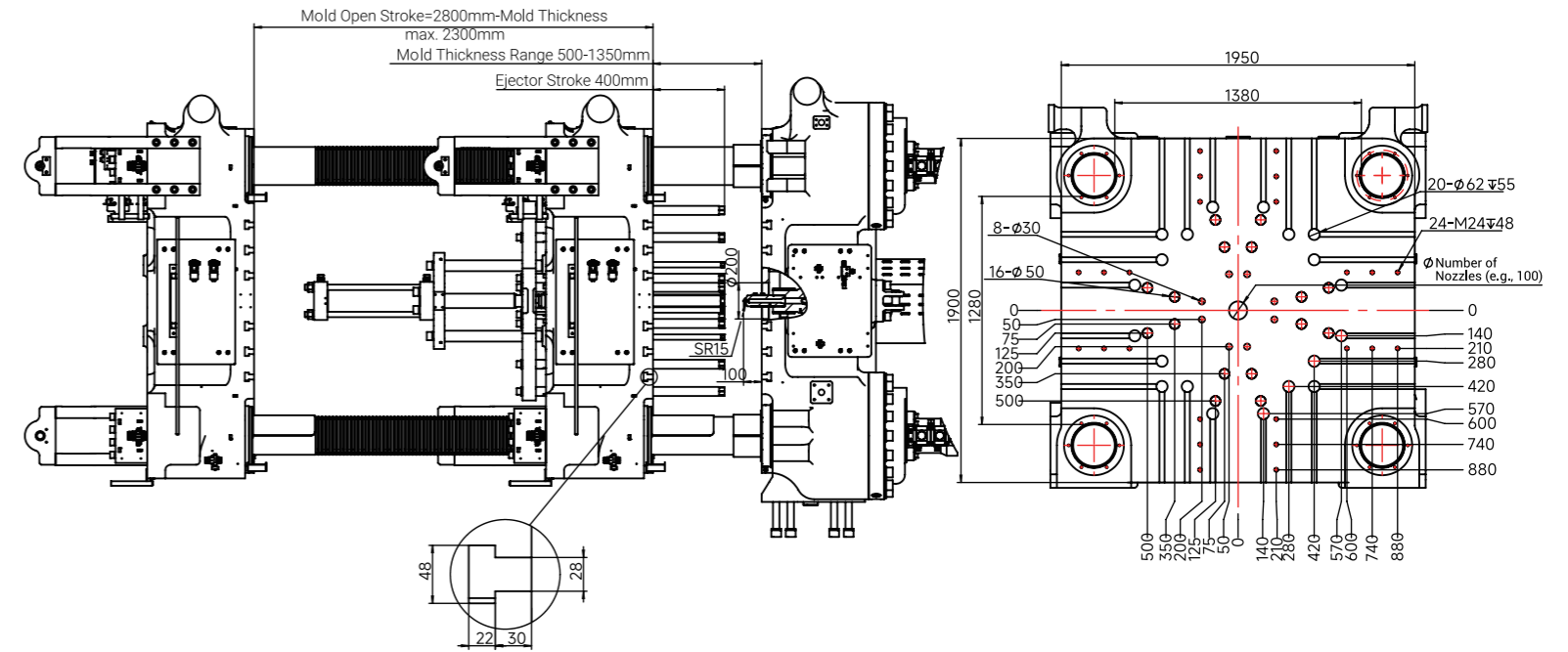

		12500			15500		
Injection Unit		A	B	C	A	B	C
Screw Diameter	mm	110	120	130	120	130	140
Screw L/D Ratio	L/D	24	22	20.3	23.8	22	20.4
Screw Stroke	mm	600			650		
Swept Volume	cm ³	5699	6782	7960	7347	8623	10001
Shot Weight (PS)	g	5186	6172	7244	6686	7847	9101
	oz	182.9	217.7	255.5	235.9	276.8	321
Maximum Injection Pressure	kgf/cm ²	2187	1838	1566	2109	1797	1550
Injection Speed	cm ³ /s	880	1048	1229	1037	1217	1412
Screw Rotation Speed (Max.)	rpm	110			104		

System Pressure	kgf/cm ²	175
Servo Pump Motor Power	kW	152
Heating Capacity	kW	71
Temperature Control Zone		7

Machine Dimensions (Length x Width x Height)	m	11.9x3.5x3
Oil Tank Capacity	L	1550

* PS Density (assumed 0.91 g/cm³)

* Note: The oil tank capacity refers to the tank itself and does not include the volume within cylinders and piping. We recommend customers prepare 1.3 times the stated capacity of hydraulic oil. Specifications are subject to change without notice due to continuous technical improvements.

SM1300TP-SMART(W)

Clamping Unit

Clamping Force	ton	1300
Opening Stroke	mm	1900-2600
Space Between Tie Bars (H x V)	mm	1670x1330
Mold Thickness (Min-Max)	mm	700-1400
Max. Daylight	mm	3300
Ejection Force	ton	22
Ejection Stroke	mm	400
Mold Register Hole	mm	200

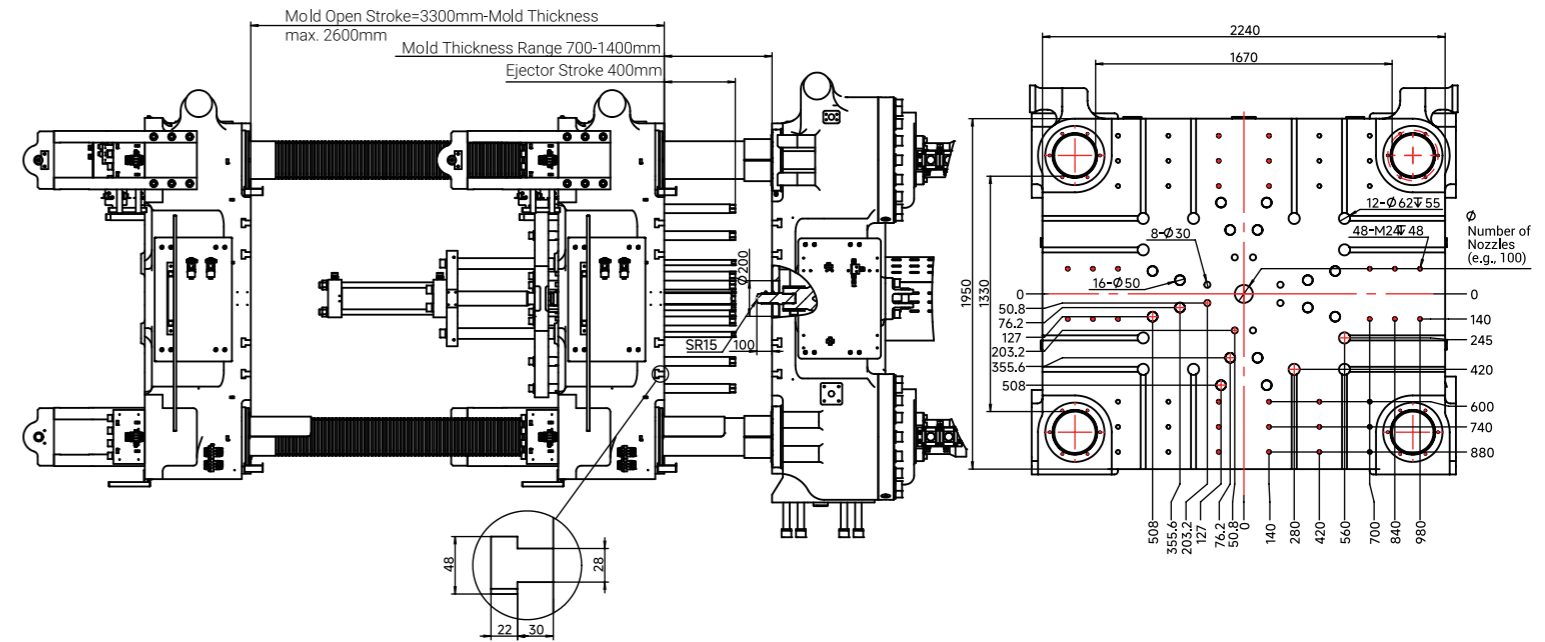

9600

Injection Unit

		A	B	C
Screw Diameter	mm	98	110	120
Screw L/D Ratio	L/D	24.7	22	20.2
Screw Stroke	mm	550		
Swept Volume	cm ³	4146	5224	6217
Shot Weight (PS)	g	3773	4754	5658
	oz	133.1	167.7	199.6
Maximum Injection Pressure	kgf/cm ²	2315	1838	1544
Injection Speed	cm ³ /s	731	921	1096
Screw Rotation Speed (Max.)	rpm	116		

Electrical/Heating

System Pressure	kgf/cm ²	175
Servo Pump Motor Power	kW	117
Heating Capacity	kW	60
Temperature Control Zone		7

Other

Machine Dimensions (Length x Width x Height)	m	11.8x3.9x3.5
Oil Tank Capacity	L	1250

12500

			A	B	C			
	A	B	C		A	B	C	
	110	120	130		120	130	140	
	24	22	20.3		23.8	22	20.4	
	600				650			
	5699	6782	7960		7347	8623	10001	
	5186	6172	7244		6686	7847	9101	
	182.9	217.7	255.5		235.9	276.8	321	
	2187	1838	1566		2109	1797	1550	
	880	1048	1229		1037	1217	1412	
	110				104			

175

152

71

7

175

176

78

7

12.5x3.9x3.5

1550

12.5x3.9x3.5

1650

SM1500TP-SMART

Clamping Unit

Clamping Force	ton	1500
Opening Stroke	mm	1550-2450
Space Between Tie Bars (H x V)	mm	1470x1370
Mould Thickness (Min-Max)	mm	550-1450
Max. Daylight	mm	3000
Ejection Force	ton	35
Ejection Stroke	mm	400
Mould Register Hole	mm	250

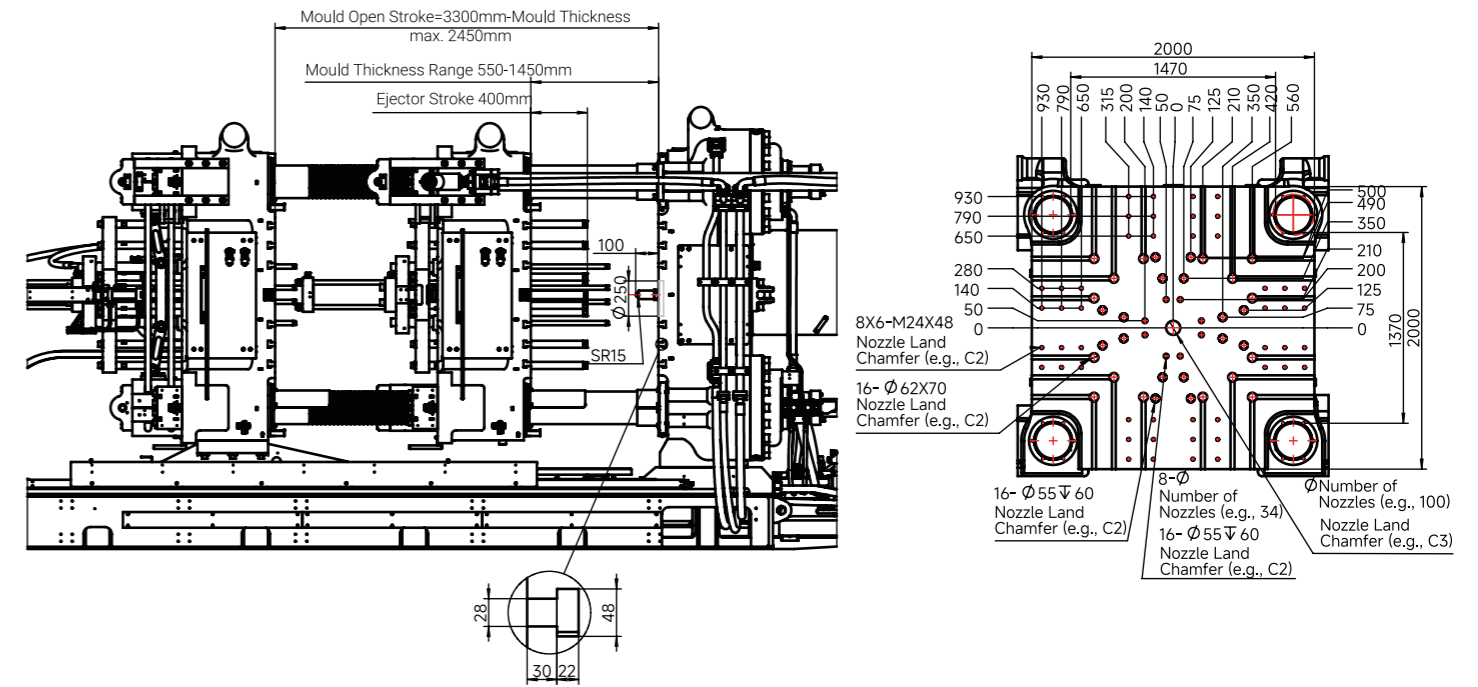

		9600		
Injection Unit		A	B	C
Screw Diameter	mm	98	110	120
Screw L/D Ratio	L/D	24.7	22	20.2
Screw Stroke	mm	550		
Swept Volume	cm ³	4146	5224	6217
Shot Weight (PS)	g	3773	4754	5658
	oz	133.1	167.7	199.6
Maximum Injection Pressure	kgf/cm ²	2315	1838	1544
Injection Speed	cm ³ /s	731	921	1096
Screw Rotation Speed (Max.)	rpm	116		

Electrical/Heating

System Pressure	kgf/cm ²	175
Servo Pump Motor Power	kW	117
Heating Capacity	kW	60
Temperature Control Zone		7

Other

Machine Dimensions (Length x Width x Height)	m	11.8x3.8x3
Oil Tank Capacity	L	1250

		12500			15500		
Injection Unit		A	B	C	A	B	C
Screw Diameter	mm	110	120	130	120	130	140
Screw L/D Ratio	L/D	24	22	20.3	23.8	22	20.4
Screw Stroke	mm	600			650		
Swept Volume	cm ³	5699	6782	7960	7347	8623	10001
Shot Weight (PS)	g	5186	6172	7244	6686	7847	9101
	oz	182.9	217.7	255.5	235.9	276.8	321
Maximum Injection Pressure	kgf/cm ²	2187	1838	1566	2109	1797	1550
Injection Speed	cm ³ /s	880	1048	1229	1037	1217	1412
Screw Rotation Speed (Max.)	rpm	110			104		
System Pressure	kgf/cm ²	175			175		
Servo Pump Motor Power	kW	152			176		
Heating Capacity	kW	71			78		
Temperature Control Zone		7			7		
Machine Dimensions (Length x Width x Height)	m	12.5x3.8x3			12.6x3.8x3		
Oil Tank Capacity	L	1550			1650		

SM1700TP-SMART

Clamping Unit

Clamping Force	ton	1700
Opening Stroke	mm	1550-2500
Space Between Tie Bars (H x V)	mm	1570x1470
Mold Thickness (Min-Max)	mm	600-1550
Max. Daylight	mm	3100
Ejection Force	ton	35
Ejection Stroke	mm	400
Mold Register Hole	mm	250

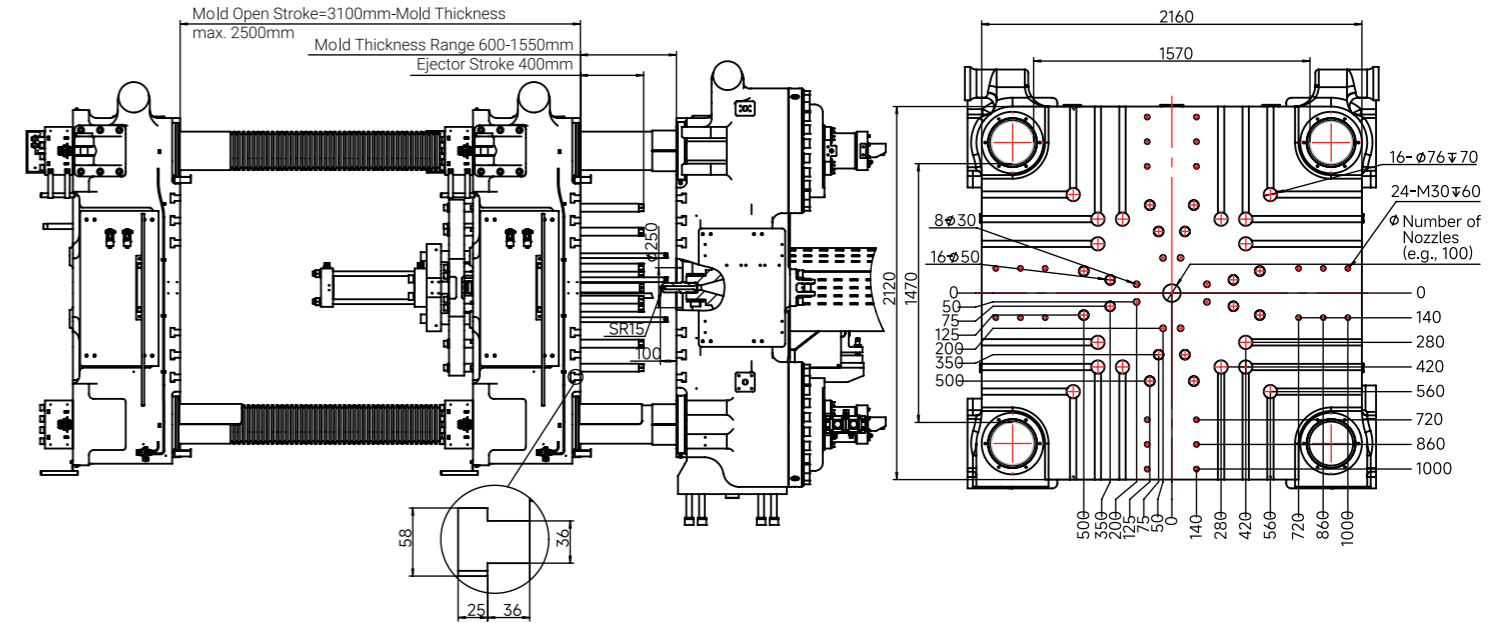

		9600		
Injection Unit		A	B	C
Screw Diameter	mm	98	110	120
Screw L/D Ratio	L/D	24.7	22	20.2
Screw Stroke	mm	550		
Swept Volume	cm ³	4146	5224	6217
Shot Weight (PS)	g	3773	4754	5658
	oz	133.1	167.7	199.6
Maximum Injection Pressure	kgf/cm ²	2315	1838	1544
Injection Speed	cm ³ /s	731	921	1096
Screw Rotation Speed (Max.)	rpm	116		

Electrical/Heating

System Pressure	kgf/cm ²	175
Servo Pump Motor Power	kW	117
Heating Capacity	kW	60
Temperature Control Zone		7

Other

Machine Dimensions (Length x Width x Height)	m	11.8x3.9x3.5
Oil Tank Capacity	L	1250

		12500			15500		
Injection Unit		A	B	C	A	B	C
Screw Diameter	mm	110	120	130	120	130	140
Screw L/D Ratio	L/D	24	22	20.3	23.8	22	20.4
Screw Stroke	mm	600			650		
Swept Volume	cm ³	5699	6782	7960	7347	8623	10001
Shot Weight (PS)	g	5186	6172	7244	6686	7847	9101
	oz	182.9	217.7	255.5	235.9	276.8	321
Maximum Injection Pressure	kgf/cm ²	2187	1838	1566	2109	1797	1550
Injection Speed	cm ³ /s	880	1048	1229	1037	1217	1412
Screw Rotation Speed (Max.)	rpm	110			104		
System Pressure	kgf/cm ²	175			175		
Servo Pump Motor Power	kW	152			176		
Heating Capacity	kW	71			78		
Temperature Control Zone		7			7		
Machine Dimensions (Length x Width x Height)	m	12.5x3.9x3.5			12.6x3.9x3.3		
Oil Tank Capacity	L	1550			1650		