



YouTube



Facebook



LinkedIn

CHEN HSONG

Add.: Unit 2001, 20th Floor, Citicorp
Centre, 18 Whitfield Road,
Hong Kong

Tel.: +852 2665-3888 | 2665-3222

Email: mr@chenhsong.com

Web.: www.chenhsong.com

CH 20260403-CV

MK6

Servo-Driven Injection Molding Machine

800-1650T



CHEN HSONG

Powering Your Future in Intelligent Injection Molding

Driven by its founding principle, "Your Vision is Our Mission", the Chen Hsong Group, established in 1958 and publicly listed in Hong Kong since 1991, has evolved over nearly 70 years from an injection molding machine manufacturer into a one-stop total solutions provider in plastics manufacturing. As one of the world's largest producers of injection molding machines, Chen Hsong achieves unmatched quality through complete in-house manufacturing. This vertically integrated approach means controlling everything from ductile iron castings, parts fabrication and core components (such as advanced controllers) to final assembly. With a comprehensive product matrix serving diverse industries like automotive and medical, we are also spearheading smart manufacturing upgrades through the iChen™ Smart Family Suite, including the iChen™ Smart Factory MES, iChen™ Cloud platform, and iChen™ AI Molder, making the path to Industry 4.0 easily accessible for our global clientele.

1,000,000m²

R&D and Production Facilities (Five locations)

85+

Countries Globally

1,000,000+

Injection Molding Machines in the Field



Hong Kong Headquarters



Shenzhen Industrial Park Facility **560000m²**



Taiwan Taoyuan Facility **30000m²**



Foshan Shunde - Two Facilities **150000m²**



Zhejiang Ningbo Facility **70000m²**



Shanwei Luhe Facility **62360m²**

Over 1 Million+ Chen Hsong Machines Are in Operation Worldwide.

They all use Chen Hsong.

Core Values

High Speed, Short Cycle Time

With a clamping force of 1000T, the fastest dry cycle time reaches 4.5 seconds

Unmatched Precision and Stability

Product repeatability accuracy error less than $\pm 0.25\%$, ensuring uniform product quality across batches

Supreme Energy Efficiency

Awarded with a Level 1 energy-saving certification, ensuring maximum reduction in energy consumption

Main Application Fields



Automotive



Households



Consumer Electronics



Logistics



Environmental Protection

Clamping Force:

800-1650T

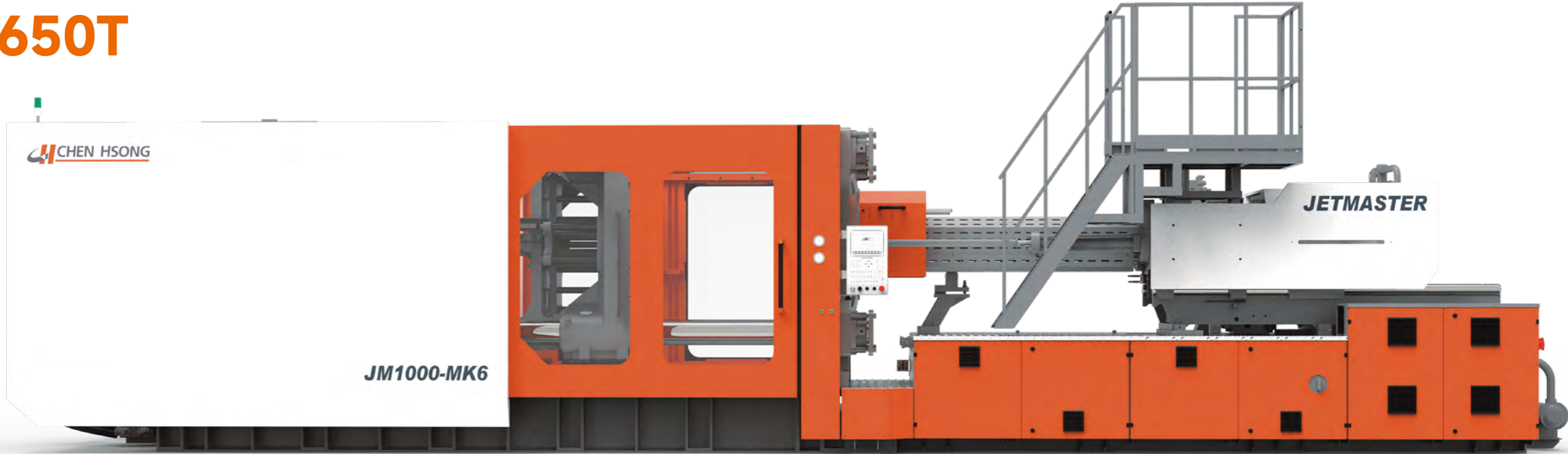

This data is test data from the Chen Hsong Innovation Technology Centre.

Clamping Unit

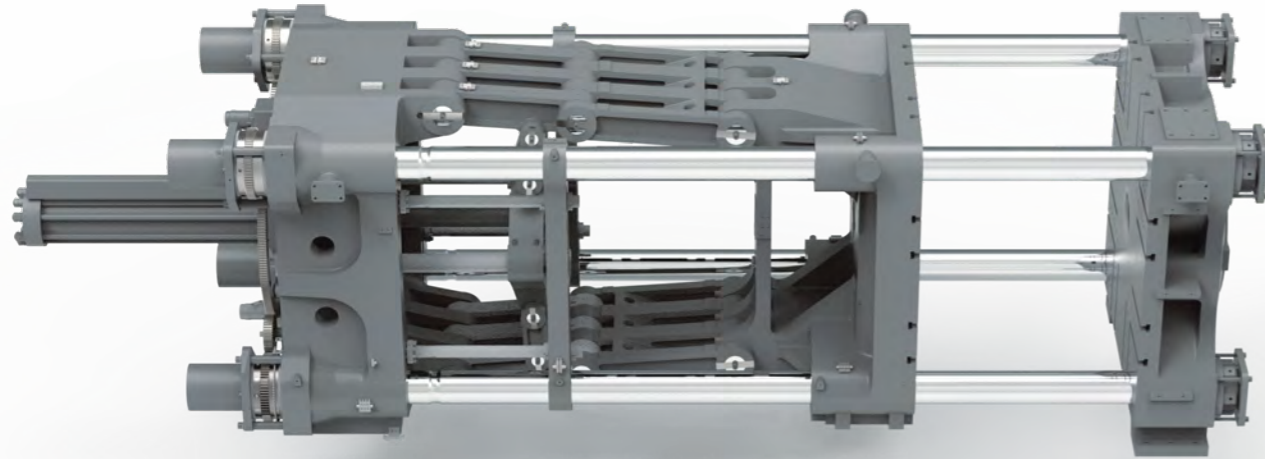

High-Strength Chrome-Plated Tie Bars

- Chrome-plating process improves the guide posts' hardness and resistance to twisting, maintaining excellent performance and longevity even in high-load situations.
- Ensures stability and precision of the mould during the injection moulding process.

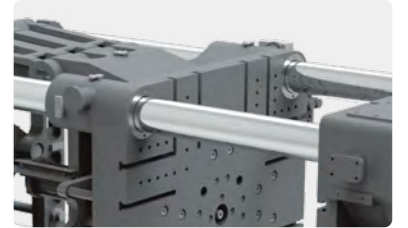

Forced Reset Mechanism

- Straightforward design for stable, reliable operation and high ejection efficiency.
- Designed for easy disassembly and reassembly, compatible with forced reset moulds.
- Accommodates a wider variety of complex moulds, expanding the machine's applicability.



Automatic Lubrication System

- Equipped with electric lubrication pump and volumetric distributors.
- Guarantees continuous lubrication for hinges and crucial parts, significantly lowering the risk of malfunctions and enhancing the machine's stability and dependability.
- Cuts down on manual maintenance effort, ensuring even and consistent lubrication across vital components.



High-Strength Circular Platen

- The design reduces platen deformation by 25% under equivalent loads, ensuring a more uniform stress distribution and providing robust protection for the Mold.
- Supports precise moulding processes, mitigating risks of product weight variance or deformation due to platen warping.



One-button automatic mold adjustment

- As fast as 15 seconds. Simple and easy to operate.



Safety Door with Electrical and Hydraulic Interlock Safety Protection

- Effectively enhances the safety and reliability of the production process.

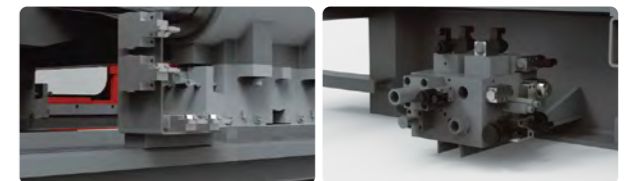

This data is test data from the Chen Hsong Innovation Technology Centre.

Hydraulic System

| New-generation servo technology

| Precision Hydraulics™

- Utilizes a highly responsive intelligent controller and closed-loop servo drive control algorithms.
- A patented technology that reduces pressure switching response times and significantly extends the life of the hydraulic pump.

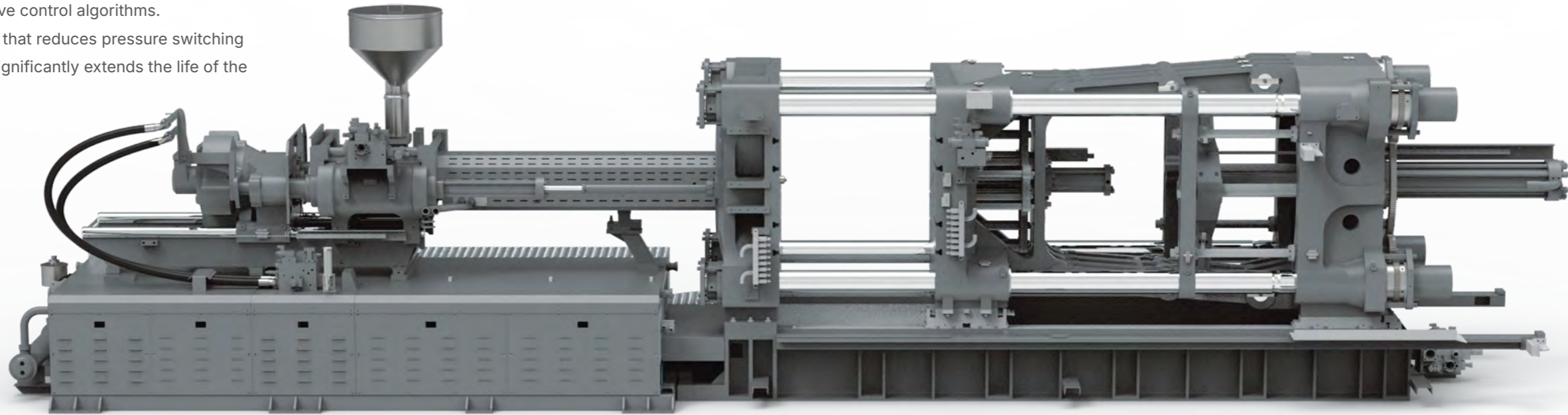

| Energy-Efficient, Low-Noise Internal Gear Pump

- Reduced Noise: Features advanced internal gear mechanisms designed to lower vibration and diminish sound levels.
- Compact and Efficient: Its streamlined and small-scale structure not only saves space but also simplifies installation and upkeep.
- Durability: Crafted from premium materials with precise manufacturing techniques for enhanced durability and a prolonged service life.



| Accurate low-pressure mold protection function

- Sophisticated control logic algorithms for precise operation under low-pressure scenarios, essential for mould integrity even at the minimal thickness level of an A4 paper (<math><0.1\text{mm}</math>). This feature is crucial for product consistency and mould safety during the production process.



This data is test data from the Chen Hsong Innovation Technology Centre.

| Servo motor drive

- Cutting-edge control algorithms for pinpoint accuracy in controlling the parameters of injection and hold pressure, significantly enhancing product precision and quality.
- Reduces the time needed for transitions between processing phases, thereby increasing overall production efficiency.
- Smart diagnostic capabilities shorten downtime and optimize equipment utilization for continuous operational efficiency.
- Highly dynamic and highly responsive, meeting the ultra-high demands of customers for better control capabilities of injection molding machines.

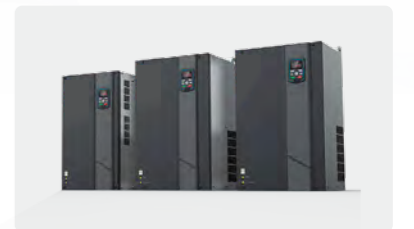

Injection Unit

High-Quality Nitrided Barrels and Screws – Standard

- Includes screws for different process requirements, versatile for various plastics.
- High-grade nitriding improves rigidity and wear resistance, increasing plasticization capacity by 7%.

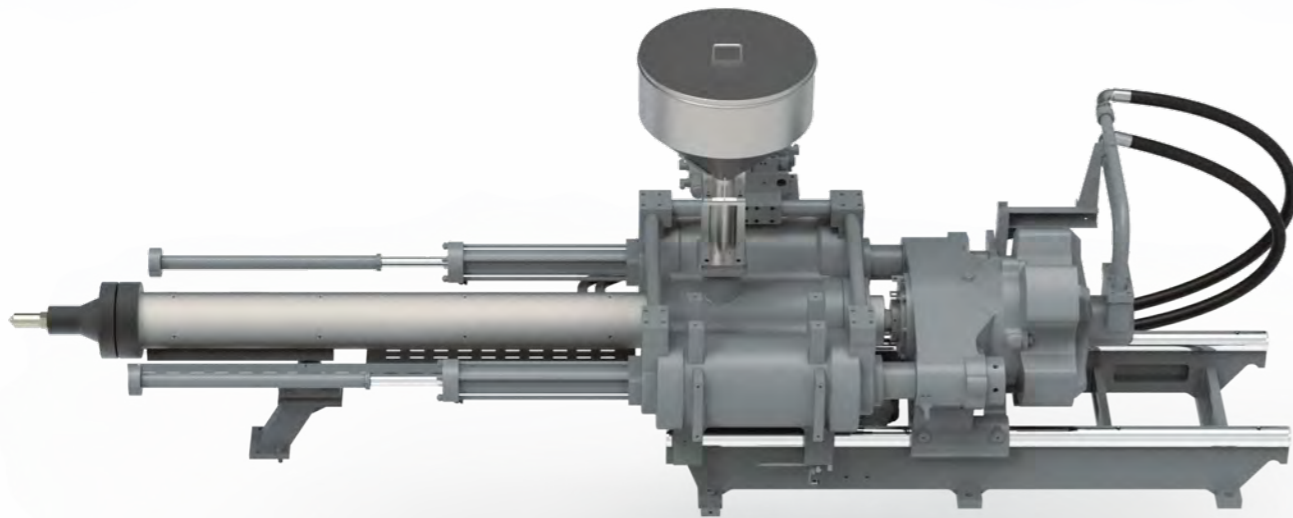

Precision Temperature PID Control

- Ensures precise and immediate temperature adjustments within the injection moulding process to maintain optimal thermal stability.

Real-time screw-rotation speed display

- Facilitate process debugging and data collection



Advanced Intelligent Computer Control System



High-Definition TFT Colour LCD Screen

- 10-inch Touch Screen Display
- Powered by a next-gen high-performance processor
- Built with all industrial-grade components, delivering both performance and reliability.
- Self-developed OS with user-centric HMI, support both touch and physical key input for simple, flexible operation.
- Multi-language support for easy global deployment, intuitive setup gets operators up to speed quickly.
- Rich communication interfaces and broad protocol compatibility enable seamless integration and strong scalability for future upgrades.

Additional Features

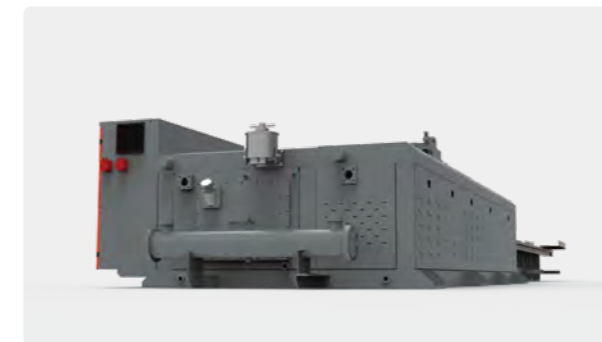

High-Rigidity Reinforced Frame

- Features an I-beam reinforced design that improves bending resistance by 7%. This enhancement ensures stable equipment operation, consistent product production, and extends the overall lifespan of the machinery.

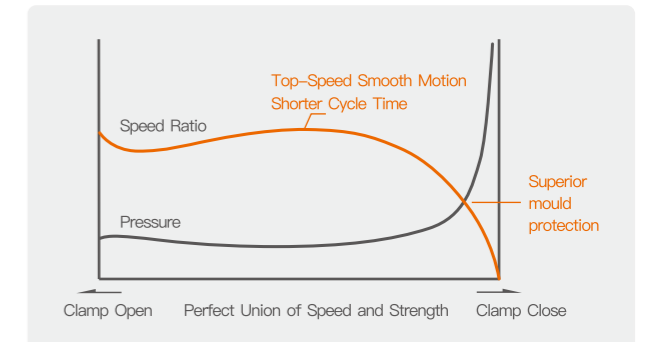

Precision Hydraulic Technology™

- Employs high-accuracy algorithms and patented technology for precise control over the hydraulic system, achieving efficient, stable, and safe production processes.

This data is test data from the Chen Hsong Innovation Technology Centre.

Specifications

INJECTION UNIT		JM800-MK6			JM1000-MK6			JM1200-MK6			JM1400-MK6			JM1650-MK6		
Screw Diameter	mm	90	98	110	98	110	120	110	120	130	120	130	140	130	140	150
Screw L/D Ratio	L/D	24	22	19.6	24.7	22	20.2	24	22	20.3	23.8	22	20.4	23.7	22	20.5
Screw Stroke	mm	500			550			600			650			700		
Injection Capacity (Theoretical)	cm ³	3179	3770	4749	4146	5224	6217	5699	6782	7960	7347	8623	10001	9286	10770	12364
Shot Weight (PS)	g	2893	3430	4322	3773	4754	5658	5186	6172	7244	6686	7847	9101	8450	9801	11251
	oz	102.1	121	152.5	133.1	167.7	199.6	182.9	217.7	255.5	235.9	276.8	321	298.1	345.7	396.9
Injection Pressure (Max.)	kgf/cm ²	2170	1840	1460	2320	1840	1550	2190	1840	1570	2110	1800	1550	2090	1800	1570
Injection Rate	cm ³ /s	607	720	907	700	885	1053	875	1045	1226	1035	1215	1409	1195	1390	1596
Screw Rotation Speed (Max.)	r/min	130			110			110			100			95		
Nozzle Contact Force	ton	16.7			16.7			16.7			16.7			16.7		
Nozzle Stroke	mm	560			595			700			720			800		
CLAMPING UNIT																
Clamping Force	ton	800			1000			1200			1400			1650		
Opening Force	mm	1050			1230			1310			1500			1600		
Space Between Tie Bar (HxV)	mm	1020×1020			1160×1160			1250×1250			1450×1350			1550×1430		
Mold Thickness (Min.-Max.)	mm	400-1000			450-1160			500-1250			650-1400			700-1500		
Maximum Daylight	mm	2050			2390			2560			2900			3100		
Injector Force	ton	18.2			21.5			21.5			35.2			35.2		
Injector Stroke	mm	280			320			320			400			400		
Mold Register Hole	mm	250			250			250			250			250		
POWER/HEATING UNIT																
System Pressure	kgf/cm ²	175			175			175			175			175		
Servo Motor Power	kW	106			118			153			176			213		
Electrical Heating Power	kW	46.7			58.7			70.1			77.4			95.2		
Temperature Heating Zone		6+1			6+1			6+1			6+1			6+1		
OTHERS																
Machine Dimensions (LxWxH)	m	11.1×2.4×2.5			11.8×2.6×3.4			12.8×2.7×3.5			13.8×3.1×3.5			14.7×3.2×3.7		
Oil Tank Capacity	L	1050			1250			1600			1750			2000		
Machine weight	ton	34			44			55			77			97		

* First oil fill: approx. 115%~120% of tank capacity.

* Technical parameters for reference only. Due to continuous product improvement, specifications subject to change without notice. Final interpretation right reserved.

* PS density: 0.91 g/cm³. Recommended shot volume: 20%~75%.

Standard features

Clamping Unit

Automatic Toggle Lubrication System

Automatic Mold Thickness and Clamping Force Adjustment

High-Strength Chrome-Plated Tie Bars

Safety Doors with Electrical and Hydraulic Interlock Protection

Differential Fast Clamping Function

Forced Reset Function

Core Pulling (2 sets)

Injection Unit

Nitrided Barrel and Screw

Temperature PID Control System

Melt Screw Speed Display

CNC Back Pressure

Nozzle Safety Shield

Screw Cold Start Prevention

Wire Break Detection

Hydraulic Unit

Low-Noise Energy-Saving Gear Pump

High-Efficiency Hydraulic Oil Cooler

Suction and Bypass Filtration Device

Hydraulic Safety Lock

Control Unit

For detailed information, refer to the CHE1.0/10T Multifunction Computer Operation Manual

Optional features

Clamping Unit

Multiple Hydraulic Ejectors

Robot Pad

EU12/EU67 Robot Interface Programming

SPI Platen

Multi-Function Air Blowing Device

Synchronized Ejector/Core Pulling

Increased Ejector Stroke

Increased Mold Capacity

Injection Unit

Barrel High Temperature Protection Cover

Smaller or Larger First Stage Injection Unit

Closed Loop Control for Material Drop

Bimetallic Barrel

Mobile Hopper

Stainless Steel Hopper

Extended Nozzle

Closed Nozzle

Chrome-Plated Nozzle

Bimetallic Screw

Ceramic Heating Rings

Infrared Heating Rings

Mixing Screw Head

Electric Pump Lubrication Device

Hydraulic Unit

Oil Temperature Control

Oil Level Indicator Alarm

Oil Pressure Rotating Demoulding

Larger First Stage Oil Motor

Larger First Stage Cooler

Increased Power

Oil Preheating

High Stability Hydraulic Control

Control Unit

B&R Controller

15-Inch Touch Screen Computer

Hot Runner Temperature Control

T slots with mounting holes

