



YouTube



Facebook



LinkedIn

**CHEN HSONG**

Add.: Unit 2001, 20th Floor, Citicorp  
Centre, 18 Whitfield Road,  
Hong Kong

Tel.: +852 2665-3888 | 2665-3222

Email: [mr@chenhsong.com](mailto:mr@chenhsong.com)

Web.: [www.chenhsong.com](http://www.chenhsong.com)

CH 20260409-CV

## **SPARK Series**

Electric Injection Molding Machines

SPARK AE, SPARK EH



# CHEN HSONG

## Powering Your Future in Intelligent Injection Molding

Driven by its founding principle, "Your Vision is Our Mission", the Chen Hsong Group, established in 1958 and publicly listed in Hong Kong since 1991, has evolved over nearly 70 years from an injection molding machine manufacturer into a one-stop total solutions provider in plastics manufacturing. As one of the world's largest producers of injection molding machines, Chen Hsong achieves unmatched quality through complete in-house manufacturing. This vertically integrated approach means controlling everything from ductile iron castings, parts fabrication and core components (such as advanced controllers) to final assembly. With a comprehensive product matrix serving diverse industries like automotive and medical, we are also spearheading smart manufacturing upgrades through the iChen™ Smart Family Suite, including the iChen™ Smart Factory MES, iChen™ Cloud platform, and iChen™ AI Molder, making the path to Industry 4.0 easily accessible for our global clientele.

**1,000,000m<sup>2</sup>**

R&D and Production Facilities  
(Five Locations)

**85+**

Countries Globally

**1,000,000+**

Injection Molding Machines in the Field

**120+**

Global Technical & Service Centres



Hong Kong Headquarters



Shenzhen Industrial Park Facility — 560000m<sup>2</sup>



Taiwan Taoyuan Facility — 30000m<sup>2</sup>



Foshan Shunde - Two Facilities — 150000m<sup>2</sup>



Zhejiang Ningbo Facility — 70000m<sup>2</sup>



Shanwei Luhe Facility — 62360m<sup>2</sup>

## Over 1 Million+ Chen Hsong Machines Are in Operation Worldwide.

They all use Chen Hsong.

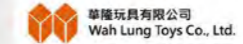

# SPARK Series | All-Electric · Electric

**SPARK AE**  
All-Electric  
20-650T



**SPARK EH**  
Electric-Hydraulic  
100-650T



Precision and efficiency achieved together,  
meeting the dual standards of complex and  
high-precision components.

\* The above product pictures are for reference only. Please refer to actual product drawings.

# SPARK Series | Four Innovative Technologies of All-Electric Injection Molding Machines



## High-Rigidity Integrated Injection

- A high-rigidity, integrated injection base ensures exceptionally stable and reliable machine operation.
- Linear guide rails supports ensure highly stable, smooth, and precise injection actions.
- Its simple structure with minimal assembly errors boosts injection precision and guarantees molded product quality.
- A rotatable injection unit simplifies both operation and maintenance.



## Modular Flexibility

- A single clamping unit accommodates a wide range of interchangeable injection components.
- Each injection unit offers a choice of two distinct injection speeds for optimised processing.
- The injection base flexibly pairs with numerous screw types to suit diverse material applications.
- This comprehensive modularity fully satisfies a wide range of product manufacturing demands.



## Intelligent Stress Release System

- Auto Stress Release System (ASRS)  
This innovative technology enables rapid molding process monitoring in under 1ms, using patented pressure relief to eliminate internal stress and ensure ultra-high product qualification rates.



## Intelligent Linkage Protection Technology

- AxP with Floating Point Toggle  
This advanced safety system, utilising precise electronics and algorithms, dynamically adjusts the ball screw for collision protection, ensuring gentle, balanced mold clamping while saving energy, reducing noise, and shortening cycle times.

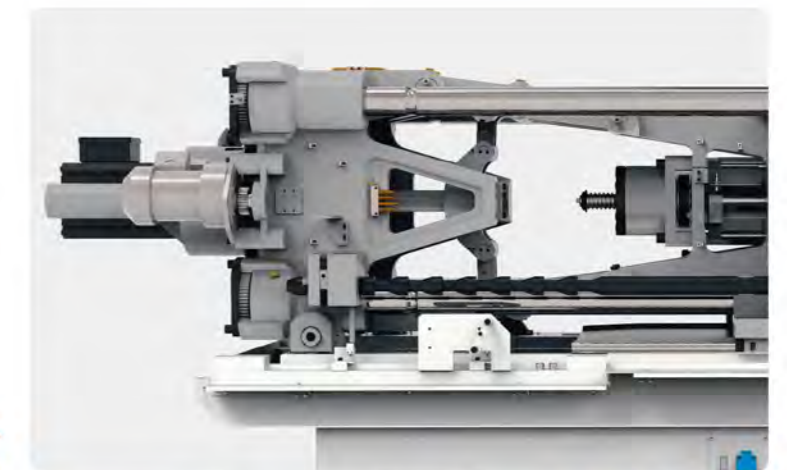

# SPARK Series | Modular Injection Unit Assembly

Machine Model \ Injection Unit	IU36h	IU80h	IU110h	IU160/160h /160hs	IU210/210h /210hs	IU330/330h /330hs	IU450/450h /450hs	IU640/640h /640hs	IU890/890h /890hs	IU1100/1100h /1100hs	IU1400/1400h /1400hs	IU1800/1800h /1800hs	IU2700 /2700h	IU3600 /3600h	IU5200
AE20	14/16/18														
AE40	14/16/18	18/20/22													
AE60		18/20/22	20/22/26												
AE/EH100			20/22/26	26/28/30	26/28/30/32/36										
AE/EH120				26/28/30	26/28/30/32/36	30/32/36/40	36/40/45								
AE/EH150					26/28/30/32/36	30/32/36/40	36/40/45	40/45/50							
AE/EH180						30/32/36/40	36/40/45	40/45/50	45/50/55						
AE/EH230							36/40/45	40/45/50	45/50/55	50/55/60					
AE/EH300									45/50/55	50/55/60	55/60/65	60/65/70			
AE/EH360										50/55/60	55/60/65	60/65/70	67/75/83		
AE/EH450											55/60/65	60/65/70	67/75/83	75/83/90	
AE/EH550												60/65/70	67/75/83	75/83/90	83/90/98
AE/EH650													67/75/83	75/83/90	83/90/98



\* The company keeps upgrading the products and reserves the right to change the product specifications and parameters without prior notice.  
The final interpretation to the above specifications and parameters belongs to the company.

# SPARK Series | Clamping Unit

## 1 Patented Circular Platen (Patent No.: ZL2019 2 1456799.X)

- Compared to conventional platens, the circular platen ensures uniform force distribution, offering better protection for the mold.
- High rigidity and stability ensure consistent product dimensions, flash-free molding, and minimal platen deformation.

## 3 Linear Guides Standard on Full Stroke

- Ensures high repeatability positioning accuracy for mold opening and closing.

## 2 Non-Contact Tie Bars

- Reduces wear and noise, minimises grease contamination on the mold mounting surface, and ensures product cleanliness.

## 4 Standard European-Style Centre Ejection

- Supports compatibility with applications requiring higher injection speeds, enabling the production of complex parts and expanding the machine's application range.

\* The above product pictures are for reference only. Please refer to actual product drawings.

# SPARK Series | Injection Unit

## 5 ALL-Adapt™ Universal Application Technology

- A single machine meets the demands of high-speed injection for complex, thin-wall parts (Standard: 350mm/s for AE series [250mm/s for models >360 tons], 200mm/s for EH series), supports optional higher injection speeds (up to 500mm/s), and provides high-pressure holding for thick-wall parts.
- Adheres to stringent requirements for performance margin overflow.

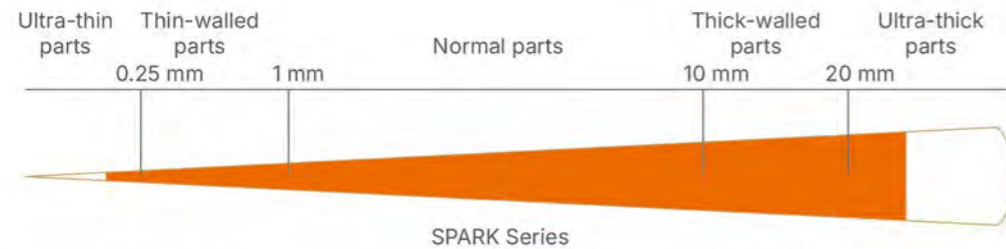

## 6 Closed-Loop Injection Pressure Control

- Actual tests and comparisons confirm that the SPARK all-electric machine offers more stable injection pressure and leads the industry in maximum holding time.

## 7 High Power Density Ceramic Heater

- Excellent thermal conductivity enables reaching preset temperatures quickly, enhancing plasticising efficiency.

## 9 Electric Screw Plasticising

- Increases plasticising efficiency by 30% and achieves up to 30% energy savings, with particularly significant effects when producing small, precision parts. (Varies depending on operating conditions)

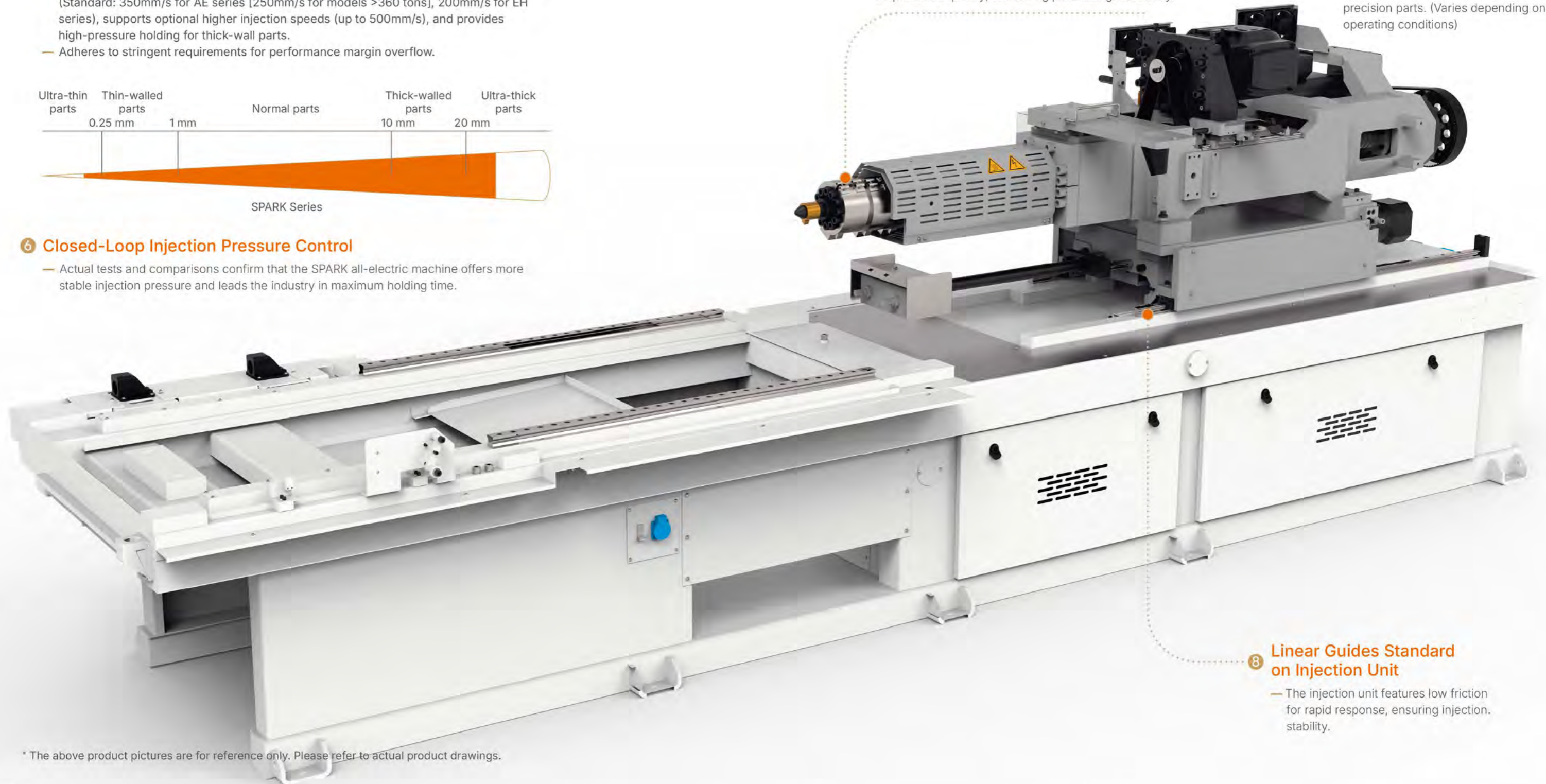

## 8 Linear Guides Standard on Injection Unit

- The injection unit features low friction for rapid response, ensuring injection stability.

\* The above product pictures are for reference only. Please refer to actual product drawings.

# SPARK Series | Control Unit



## ⑩ 15-Inch Touchscreen HMI

- 
 — Full-Cycle Monitoring  
 Enables data monitoring across the entire cycle: injection, holding, plasticising, mold open/close.
- 
 — High-Speed Control Response  
 High-performance computer chip responds to and executes commands with ultra-fast processing capability.
- 
 — Intelligent Stress Relief System  
 Monitors screw movement status during injection at extreme speed (<1ms). The patented venting and pressure relief mechanism design releases internal stress.



Chen Hsong's all-electric injection molding machine realizes the servo STO function and has passed the TÜV safety certification. (Technischer Überwachungs-Verein)

China energy saving injection molding machine identification



## ⑪ 4 Dedicated IPM Servo Motors

- Independently control injection, holding, plasticising, mold open/close, and ejection actions, ensuring every action throughout the injection molding cycle is fast, precise, efficient, and energy-saving.

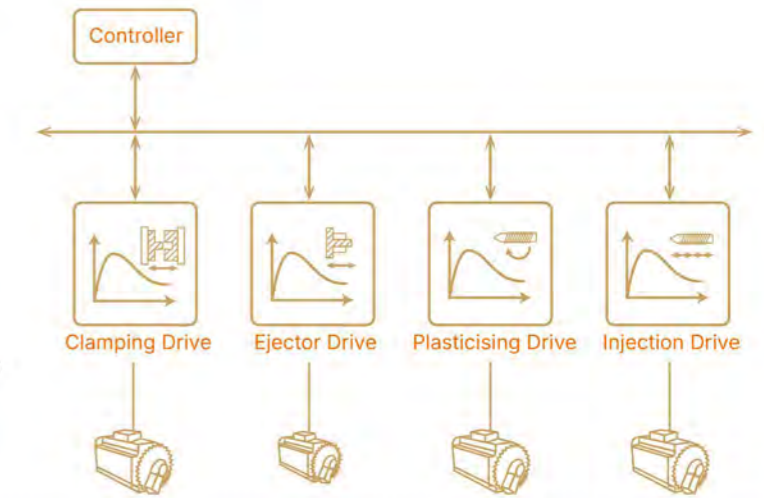

- High-sensitivity dynamic response servo motor system



\* The above product pictures are for reference only. Please refer to actual product drawings.

# iChen™ Smart Family

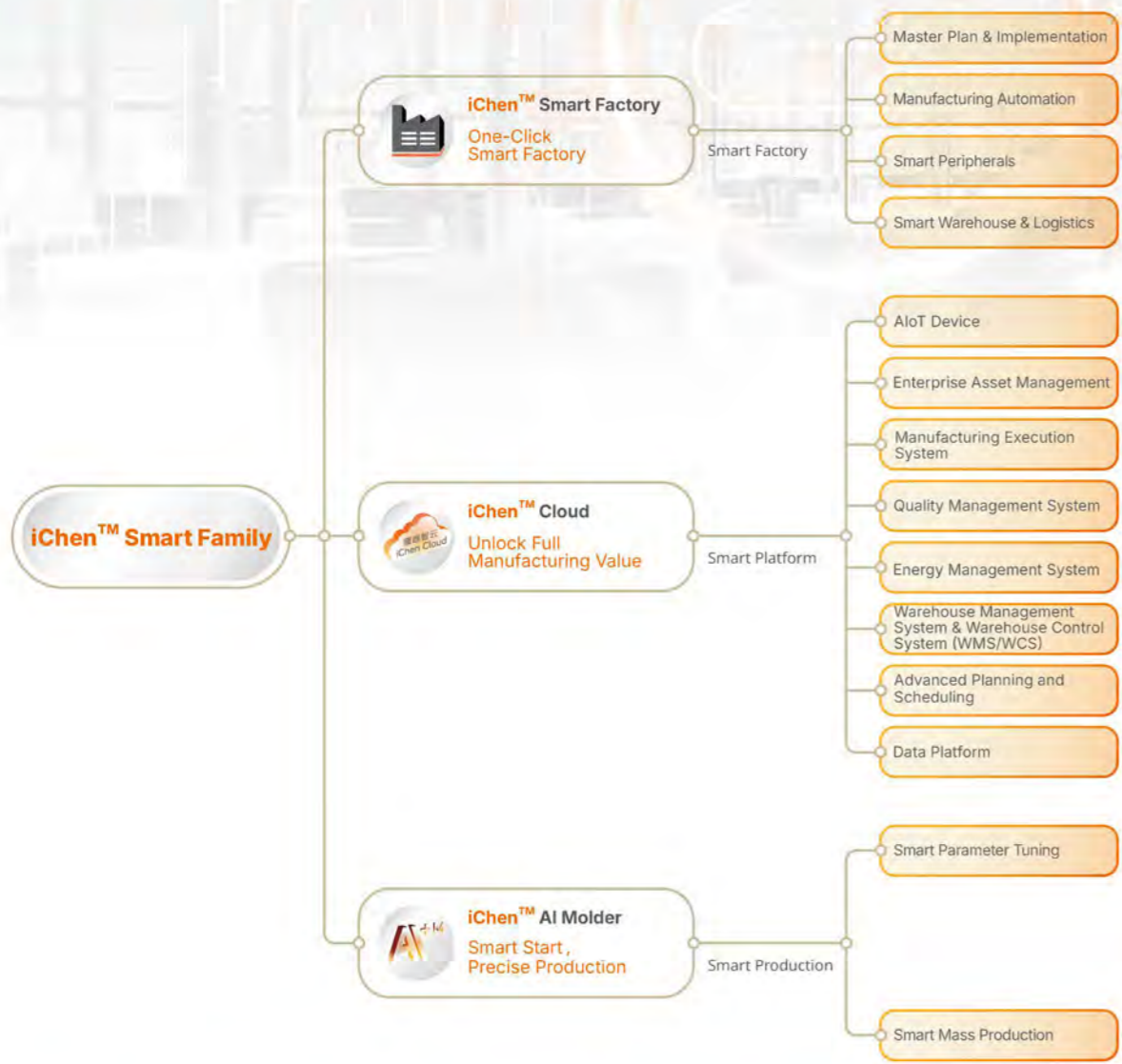

## iChen™ Smart Factory

One-Click Smart Factory

iChen™ Smart Factory delivers plant-wide, end-to-end line engineering and integration. Covering planning and design, auxiliary-system configuration, automation, smart peripherals, and warehouse and logistics setup, we integrate the entire production chain and deliver complete turnkey factory projects.

## iChen™ Cloud

Unlock Full Manufacturing Value

iChen™ Cloud is a Smart Manufacturing Operations Management Platform covering Artificial Intelligence Internet of Things (AIoT), Enterprise Asset Management (EAM), Manufacturing Execution System (MES), Quality Management System (QMS), Energy Management System (EMS), Warehouse Management System & Warehouse Control System (WMS/WCS), Advanced Planning and Scheduling (APS), and the Data Platform. Together, these enable end-to-end digital control with real-time visibility and executive dashboards for faster, data-driven decisions.

## iChen™ AI Molder

Smart Start, Precise Production

iChen™ AI Molder is an AI-driven injection-molding solution developed by Chen Hsong Group in collaboration with industry-academia research teams. It integrates AI with injection-molding process expertise to recommend and optimize parameters, stabilize mass production, reduce defects, and increase yield.



# iChen™ Smart Family

# SPARK AE | Specifications

Specifications	Unit	AE20			AE40			AE60			AE100																											
Injection Unit		A	B	C	A	B	C	A	B	C	A	B	C	A	B	C	A	B	C	A2	A1	A	B	C														
Screw Diameter	mm	14	16	18	14	16	18	18	20	22	18	20	22	20	22	26	20	22	26	26	28	30	26	28	30	32	36											
Screw L/D Ratio	/	22	20	19	22	20	19	22	20	19	22	20	19	22	20	19	22	20	19	21	21	21	21	21	21	21	21											
Theoretical Shot Volume	cm <sup>3</sup>	11	15	19	11	15	19	25	31	38	25	31	38	34	41	58	34	41	58	62	72	83	62	78	89	101	128											
Shot Weight (PS)	g	10	14	17	10	14	17	23	28	35	23	28	35	31	37	53	31	37	53	56	65	75	56	70	80	91	116											
Injection Pressure	MPa	290	240	186	290	240	186	300	250	210	300	250	210	280	240	170	280	240	170	255	220	192	303	261	228	200	158											
Holding Pressure	MPa	247	204	158	247	204	158	255	213	179	255	213	179	238	204	145	238	204	145	204	176	154	242	209	182	160	126											
Injection Unit Model		36h			36h			80h			80h			110h			110h			160h			210h															
Injection Rate	cm <sup>3</sup> /s	59	80	101	59	80	101	100	124	152	100	124	152	108	130	185	108	130	185	185	215	248	185	217	247	281	356											
Injection Speed	mm/s	400	400	400	400	400	400	400	400	400	400	400	400	350	350	350	350	350	350	350	350	350	350	350	350	350	350											
Injection Unit Model		-			-			-			-			-			-			160			210															
Injection Rate	cm <sup>3</sup> /s	-	-	-	-	-	-	-	-	-	-	-	-	-	-	-	-	-	-	106	123	142	106	124	141	160	203											
Injection Speed	mm/s	-	-	-	-	-	-	-	-	-	-	-	-	-	-	-	-	-	-	200	200	200	200	200	200	200	200											
Injection Unit Model		-			-			-			-			-			-			160hs			210hs															
Injection Rate	cm <sup>3</sup> /s	-	-	-	-	-	-	-	-	-	-	-	-	-	-	-	-	-	-	265	308	355	265	310	353	401	508											
Injection Speed	mm/s	-	-	-	-	-	-	-	-	-	-	-	-	-	-	-	-	-	-	500	500	500	500	500	500	500	500											
Injection Stroke (Max.)	mm	75	75	75	75	75	75	100	100	100	100	100	100	110	110	110	110	110	110	117	117	117	117	126	126	126	126											
Screw Speed (Max.)	rpm	400	400	400	400	400	400	400	400	400	400	400	400	400	400	400	400	400	400	400	400	400	400	400	400	400	400											
Nozzle Contact Force (Max.)	kN	10	10	10	10	10	10	11	11	11	11	11	11	18	18	18	18	18	18	22	22	22	22	22	22	22	22											
Nozzle Stroke (Max.)	mm	250	250	250	250	250	250	250	250	250	250	250	250	250	250	250	265	265	265	265	265	265	265	265	265	265	265											
<b>Camping Unit</b>																																						
Clamping Force	kN	200			400			600			1000																											
Mold Opening Stroke	mm	210			240			330			360																											
Mold Dimensions	mm	430x420			450x450			540x540			640x590																											
Space Between Tie Bars (HxV)	mm	280x260			310x310			360x360			460x410																											
Mold Force (Min.-Max.)	mm	130-300			150-360			150-380			150-510																											
Max. Daylight	mm	510			600			710			870																											
Ejector Force	kN	9			13			18			24.5																											
Ejector Stroke	mm	50			75			100			100																											
No. of Ejector Pins	PCS	1			1			4+1			4+1																											
Locating Ring Diameter	mm	80			100			100			100																											
<b>Others</b>																																						
Total Power Capacity	kW	36h:9kW			36h:9kW			80h:13.6kW			80h:13.6kW			110h:17kW			110h:17kW			160:17kW			210:23kW			160h:24kW			210h:27kW			160hs:32kW			210hs:39kW			
Max. Rated Current	A	36h:16A			36h:16A			80h:24A			80h:24A			110h:30A			110h:30A			160:31A			210:41A			160h:42A			210h:49A			160hs:56A			210hs:69A			
Heating Power	kW	5.3	5.3	5.3	5.3	5.3	5.3	6.3	6.3	6.3	6.3	6.3	6.3	7.2	7.2	7.2	7.2	7.2	7.2	7.8	8.4	9.0	8.1	8.4	9.0	9.6	12.5											
Temperature Control Zone	Zone	2+1			2+1			3+1			3+1			3+1			3+1			3+1			3+1			3+1			4+1									
Machine Dimensions (LxWxH)	m	2.65x1.0x1.65			2.65x1.0x1.65			3.8x1.15x1.75			3.8x1.15x1.75			4.1x1.28x1.8			4.56x1.40x2.03			4.66x1.40x2.03			4.81x1.40x2.03															
Machine Weight	T	1.4			1.4			1.8			1.8			2.5			4.0			3.9			4.1															

\*To enhance the using experience, the company keeps upgrading the products and reserves the right to change the product specification and parameters without prior notice. The final interpretation to the above specification and parameters belongs to the company.

# SPARK AE | Specifications

Specifications		Unit	AE120															AE150																	
Injection Unit			A	B	C	A2	A1	A	B	C	A1	A	B	C	A	B	C	A2	A1	A	B	C	A1	A	B	C	A	B	C						
Screw Diameter	mm		26	28	30	26	28	30	32	36	30	32	36	40	36	40	45	26	28	30	32	36	30	32	36	40	36	40	45	40	45	50			
Screw L/D Ratio	/		21	21	21	21	21	21	21	21	21	21	21	21	21	21	21	21	21	21	21	21	21	21	21	21	21	21	21	21	21				
Theoretical Shot Volume	cm <sup>3</sup>		62	72	83	62	78	89	101	128	106	129	163	201	183	226	286	62	78	89	101	128	106	129	163	201	183	226	286	251	318	393			
Shot Weight (PS)	g		56	65	75	56	70	80	91	116	96	117	148	182	166	205	260	56	70	80	91	116	96	117	148	182	166	205	260	228	289	357			
Injection Pressure	MPa		255	220	192	303	261	228	200	158	288	253	200	162	247	200	158	303	261	228	200	158	288	253	200	162	247	200	158	253	200	162			
Holding Pressure	MPa		204	176	154	242	209	182	160	126	230	202	160	130	198	160	126	242	209	182	160	126	230	202	160	130	198	160	126	202	160	130			
Injection Unit Model			160h			210h			330h			450h			210h			330h			450h			640h											
Injection Rate	cm <sup>3</sup> /s		185	215	248	185	217	247	281	356	247	282	357	440	305	377	477	185	217	247	281	356	247	282	357	440	305	377	477	314	398	491			
Injection Speed	mm/s		350	350	350	350	350	350	350	350	350	350	350	350	300	300	300	350	350	350	350	350	350	350	350	350	350	350	350	350	350	350			
Injection Unit Model			160			210			330			450			210			330			450			640											
Injection Rate	cm <sup>3</sup> /s		106	123	142	106	124	141	160	203	141	161	204	251	203	251	318	106	124	141	160	203	141	161	204	251	203	251	318	201	254	314			
Injection Speed	mm/s		200	200	200	200	200	200	200	200	200	200	200	200	200	200	200	200	200	200	200	200	200	200	200	200	200	200	200	200	200	200			
Injection Unit Model			160hs			210hs			330hs			450hs			210hs			330hs			450hs			640hs											
Injection Rate	cm <sup>3</sup> /s		265	308	355	265	310	353	401	508	353	403	509	628	508	628	794	265	310	353	401	508	353	403	509	628	508	628	794	439	557	688			
Injection Speed	mm/s		500	500	500	500	500	500	500	500	500	500	500	500	500	500	500	500	500	500	500	500	500	500	500	500	500	500	500	500	500	500			
Injection Stroke (Max.)	mm		117	117	117	117	126	126	126	126	150	160	160	160	180	180	180	117	126	126	126	126	150	160	160	160	180	180	180	200	200	200			
Screw Speed (Max.)	rpm		400	400	400	400	400	400	400	400	400	400	400	400	400	400	400	400	400	400	400	400	400	400	400	400	400	400	400	400	400	400			
Nozzle Contact Force (Max.)	kN		22	22	22	22	22	22	22	22	22	22	22	22	22	22	22	29	29	29	29	29	29	29	29	29	29	29	29	29	29	29			
Nozzle Stroke (Max.)	mm		265	265	265	265	265	265	265	265	265	265	265	265	265	265	265	320	320	320	320	320	320	320	320	320	320	320	320	320	320	320			
<b>Camping Unit</b>																																			
Clamping Force	kN		1200															1500																	
Mold Opening Stroke	mm		360															420																	
Mold Dimensions	mm		640x590															730x680																	
Space Between Tie Bars (HxV)	mm		460x410															510x460																	
Mold Force (Min.-Max.)	mm		150-510															180-520																	
Max. Daylight	mm		870															940																	
Ejector Force	kN		24.5															34.3																	
Ejector Stroke	mm		100															120																	
No. of Ejector Pins	PCS		4+1															4+1																	
Locating Ring Diameter	mm		100															100																	
<b>Others</b>																																			
Total Power Capacity	kW		160: 17kW			210: 23kW			330: 25kW			450: 31kW			210: 32kW			330: 33kW			450: 40kW			640: 44kW											
			160h: 24kW			210h: 27kW			330h: 33kW			450h: 39kW			210h: 32kW			330h: 33kW			450h: 40kW			640h: 44kW											
			160hs: 32kW			210hs: 39kW			330hs: 49kW			450hs: 60kW			210hs: 39kW			330hs: 49kW			450hs: 60kW			640hs: 61kW											
Max. Rated Current	A		160: 31A			210: 41A			330: 45A			450: 56A			210: 57A			330: 59A			450: 71A			640: 77A											
			160h: 42A			210h: 49A			330h: 59A			450h: 69A			210h: 57A			330h: 59A			450h: 71A			640h: 77A											
			160hs: 56A			210hs: 69A			330hs: 87A			450hs: 106A			210hs: 69A			330hs: 87A			450hs: 106A			640hs: 108A											
Heating Power	kW		7.8	8.4	9.0	8.1	8.4	9.0	9.6	12.5	9.0	9.6	12.5	14.3	12.5	14.3	16.5	8.1	8.4	9.0	9.6	12.5	9.0	9.6	12.5	14.3	12.5	14.3	16.5	14.3	16.5	18.7			
Temperature Control Zone	Zone		3+1			3+1			4+1			3+1			4+1			3+1			4+1			3+1			4+1			4+1			4+1		
Machine Dimensions (LxWxH)	m		4.96x1.40x2.03			4.96x1.40x2.03			5.14x1.40x2.03			5.34x1.40x2.03			5.67x1.52x2.05			5.74x1.52x2.05			5.94x1.52x2.05			6.16x1.52x2.05											
Machine Weight	T		3.9			4.1			4.2			4.3			5.8			6.5			6.8			7.0											

\*To enhance the using experience, the company keeps upgrading the products and reserves the right to change the product specification and parameters without prior notice. The final interpretation to the above specification and parameters belongs to the company.

# SPARK AE | Specifications

Specifications		Unit	AE180												AE230												
Injection Unit			A1	A	B	C	A	B	C	A	B	C	A	B	C	A	B	C	A	B	C	A	B	C			
Screw Diameter	mm		30	32	36	40	36	40	45	40	45	50	45	50	55	36	40	45	40	45	50	45	50	55	50	55	60
Screw L/D Ratio	/		21	21	21	21	21	21	21	21	21	21	21	21	21	21	21	21	21	21	21	21	21	21	21	21	21
Theoretical Shot Volume	cm <sup>3</sup>		106	129	163	201	183	226	286	251	318	393	358	442	535	183	226	286	251	318	393	358	442	535	491	594	707
Shot Weight (PS)	g		96	117	148	182	166	205	260	228	289	357	325	402	486	166	205	260	228	289	357	325	402	486	446	540	643
Injection Pressure	MPa		288	253	200	162	247	200	158	253	200	162	247	200	165	247	200	158	253	200	162	247	200	165	218	180	151
Holding Pressure	MPa		230	202	160	130	198	160	126	202	160	130	198	160	132	198	160	126	202	160	130	198	160	132	174	144	121
Injection Unit Model			330h			450h			640h			890h			450h			640h			890h			1100h			
Injection Rate	cm <sup>3</sup> /s		247	282	357	440	305	377	477	314	398	491	398	491	594	305	377	477	314	398	491	398	491	594	491	594	707
Injection Speed	mm/s		350	350	350	350	300	300	300	250	250	250	250	250	250	300	300	300	250	250	250	250	250	250	250	250	250
Injection Unit Model			330			450			640			890			450			640			890			1100			
Injection Rate	cm <sup>3</sup> /s		141	161	204	251	203	251	318	201	254	314	255	314	380	203	251	318	201	254	314	255	314	380	314	380	452
Injection Speed	mm/s		200	200	200	200	200	200	200	160	160	160	160	160	160	200	200	200	160	160	160	160	160	160	160	160	160
Injection Unit Model			330hs			450hs			640hs			890hs			450hs			640hs			890hs			1100hs			
Injection Rate	cm <sup>3</sup> /s		353	403	509	628	508	628	794	439	557	688	557	688	832	508	628	794	439	557	688	557	688	832	687	832	990
Injection Speed	mm/s		500	500	500	500	500	500	500	350	350	350	350	350	350	500	500	500	350	350	350	350	350	350	350	350	350
Injection Stroke (Max.)	mm		150	160	160	160	180	180	180	200	200	200	225	225	225	180	180	180	200	200	200	225	225	225	250	250	250
Screw Speed (Max.)	rpm		400	400	400	400	400	400	400	350	350	350	320	320	320	400	400	400	350	350	350	320	320	320	320	320	320
Nozzle Contact Force (Max.)	kN		39	39	39	39	39	39	39	39	39	39	39	39	39	49	49	49	49	49	49	49	49	49	49	49	49
Nozzle Stroke (Max.)	mm		340	340	340	340	340	340	340	340	340	340	340	340	340	400	400	400	400	400	400	400	400	400	400	400	400
<b>Camping Unit</b>																											
Clamping Force	kN		1800												2300												
Mold Opening Stroke	mm		480												550												
Mold Dimensions	mm		800x795.5												890x885.5												
Space Between Tie Bars (HxV)	mm		560x560												610x610												
Mold Force (Min.-Max.)	mm		200-600												250-680												
Max. Daylight	mm		1080												1230												
Ejector Force	kN		34.3												51.9												
Ejector Stroke	mm		120												150												
No. of Ejector Pins	PCS		12+1												12+1												
Locating Ring Diameter	mm		120												125												
<b>Others</b>																											
Total Power Capacity	kW		330: 33kW			450: 40kW			640: 44kW			890: 48kW			450: 43kW			640: 46kW			890: 51kW			1100: 63kW			
			330h: 33kW			450h: 40kW			640h: 44kW			890h: 48kW			450h: 43kW			640h: 46kW			890h: 51kW			1100h: 63kW			
			330hs: 49kW			450hs: 60kW			640hs: 61kW			890hs: 67kW			450hs: 60kW			640hs: 61kW			890hs: 67kW			1100hs: 76kW			
Max. Rated Current	A		330: 59A			450: 71A			640: 77A			890: 85A			450: 76A			640: 82A			890: 90A			1100: 111A			
			330h: 59A			450h: 71A			640h: 77A			890h: 85A			450h: 76A			640h: 82A			890h: 90 A			1100h: 111A			
			330hs: 87A			450hs: 106A			640hs: 108A			890hs: 118A			450hs: 106A			640hs: 108A			890hs: 118A			1100hs: 135A			
Heating Power	kW		9.0	9.6	12.5	14.3	12.5	14.3	16.5	14.3	16.5	18.7	16.5	18.7	24.0	12.5	14.3	16.5	14.3	16.5	18.7	16.5	18.7	24.0	18.7	24.0	26.8
Temperature Control Zone	Zone		3+1			4+1			4+1			4+1			4+1			4+1			4+1			4+1			
Machine Dimensions (LxWxH)	m		6.33x1.63x2.19			6.33x1.63x2.19			6.44x1.63x2.19			6.75x1.63x2.19			6.82x1.72x2.30			6.83x1.72x2.30			7.14x1.72x2.30			7.37x1.72x2.30			
Machine Weight	T		7.4			7.7			8.0			8.3			10.2			10.5			10.8			11.2			

\*To enhance the using experience, the company keeps upgrading the products and reserves the right to change the product specification and parameters without prior notice. The final interpretation to the above specification and parameters belongs to the company.

# SPARK AE | Specifications

Specifications		Unit	AE300												AE360											
Injection Unit			A	B	C	A	B	C	A	B	C	A	B	C	A	B	C	A	B	C	A	B	C			
Screw Diameter	mm		45	50	55	50	55	60	55	60	65	60	65	70	50	55	60	55	60	65	60	65	70	67	75	83
Screw L/D Ratio	/		21	21	21	21	21	21	21	21	22	21	22	22	21	21	21	21	21	22	21	22	22	23.5	21	19
Theoretical Shot Volume	cm <sup>3</sup>		358	442	535	491	594	707	653	778	913	848	995	1155	491	594	707	653	778	913	848	995	1155	1181	1480	1813
Shot Weight (PS)	g		325	402	486	446	540	643	594	707	830	771	905	1051	446	540	643	594	707	830	771	905	1051	1074	1346	1649
Injection Pressure	MPa		247	200	165	218	180	151	214	180	153	211	180	155	218	180	151	214	180	153	211	180	155	226	180	147
Holding Pressure	MPa		198	160	132	174	144	121	171	144	122	169	144	124	174	144	121	171	144	122	169	144	124	181	144	118
Injection Unit Model			890h			1100h			1400h			1800h			1100h			1400h			1800h			2700h		
Injection Rate	cm <sup>3</sup> /s		398	491	594	491	594	707	594	707	830	707	829	963	491	594	707	594	707	830	707	829	963	881	1104	1353
Injection Speed	mm/s		250	250	250	250	250	250	250	250	250	250	250	250	250	250	250	250	250	250	250	250	250	250	250	250
Injection Unit Model			890			1100			1400			1800			1100			1400			1800			2700		
Injection Rate	cm <sup>3</sup> /s		255	314	380	314	380	452	380	453	531	452	531	616	314	380	452	380	453	531	452	531	616	564	707	866
Injection Speed	mm/s		160	160	160	160	160	160	160	160	160	160	160	160	160	160	160	160	160	160	160	160	160	160	160	160
Injection Unit Model			890hs			1100hs			1400hs			1800hs			1100hs			1400hs			1800hs			-		
Injection Rate	cm <sup>3</sup> /s		557	688	832	687	832	990	831	990	1162	989	1161	1348	687	832	990	831	990	1162	989	1161	1348	-	-	-
Injection Speed	mm/s		350	350	350	350	350	350	350	350	350	350	350	350	350	350	350	350	350	350	350	350	350	-	-	-
Injection Stroke (Max.)	mm		225	225	225	250	250	250	275	275	275	300	300	300	250	250	250	275	275	275	300	300	300	335	335	335
Screw Speed (Max.)	rpm		320	320	320	320	320	320	300	300	300	250	250	250	320	320	320	300	300	300	250	250	250	250	250	250
Nozzle Contact Force (Max.)	kN		54	54	54	54	54	54	54	54	54	54	54	54	54	54	54	54	54	54	54	54	54	54	54	54
Nozzle Stroke (Max.)	mm		400	430	430	430	430	430	430	430	430	430	430	430	430	430	430	430	430	430	430	430	430	430	430	430
<b>Camping Unit</b>																										
Clamping Force	kN		3000												3600											
Mold Opening Stroke	mm		600												700											
Mold Dimensions	mm		1080x1070												1160x1165											
Space Between Tie Bars (HxV)	mm		730x730												830x830											
Mold Force (Min.-Max.)	mm		300-750												300-850											
Max. Daylight	mm		1350												1550											
Ejector Force	kN		62												62											
Ejector Stroke	mm		160												180											
No. of Ejector Pins	PCS		12+1												12+1											
Locating Ring Diameter	mm		160												160											
<b>Others</b>																										
Total Power Capacity	kW		890: 57kW			1100: 69kW			1400: 80kW			1800: 83kW			1100: 77kW			1400: 88kW			1800: 91kW			2700: 115kW		
			890h: 57kW			1100h: 69kW			1400h: 80kW			1800h: 83kW			1100h: 77kW			1400h: 88kW			1800h: 91kW			2700h: 115kW		
			890hs: 67kW			1100hs: 76kW			1400hs: 92kW			1800hs: 103kW			1100hs: 77kW			1400hs: 92kW			1800hs: 103kW			-		
Max. Rated Current	A		890: 100A			1100: 121A			1400: 141A			1800: 147A			1100: 136A			1400: 156A			1800: 162A			2700: 203A		
			890h: 100A			1100h: 121A			1400h: 141A			1800h: 147A			1100h: 136A			1400h: 156A			1800h: 162A			2700h: 203A		
			890hs: 118A			1100hs: 135A			1400hs: 163A			1800hs: 181A			1100hs: 136A			1400hs: 163A			1800hs: 181A			-		
Heating Power	kW		16.5	18.7	24.0	18.7	24.0	26.8	24.0	26.8	36.1	26.8	36.1	38.8	18.7	24.0	26.8	24.0	26.8	36.1	26.8	36.1	38.8	34.4	34.4	34.4
Temperature Control Zone	Zone		4+1			4+1			4+1		5+1	4+1	5+1		4+1		4+1	5+1	4+1	5+1		5+1		5+1		
Machine Dimensions (LxWxH)	m		7.75x1.98x2.47			7.78x1.98x2.47			8.13x1.98x2.47			8.31x1.98x2.47			8.65x2.14x2.50			8.65x2.14x2.50			8.82x2.14x2.50			9.15x2.14x2.50		
Machine Weight	T		14.5			14.9			15.2			15.5			17.8			18.1			18.5			18.7		

\*To enhance the using experience, the company keeps upgrading the products and reserves the right to change the product specification and parameters without prior notice. The final interpretation to the above specification and parameters belongs to the company.

# SPARK AE | Specifications

Specifications	Unit	AE450												AE550											
Injection Unit		A	B	C	A	B	C	A	B	C	A	B	C	A	B	C	A	B	C	A	B	C	A	B	C
Screw Diameter	mm	55	60	65	60	65	70	67	75	83	75	83	90	60	65	70	67	75	83	75	83	90	83	90	98
Screw L/D Ratio	/	21	21	22	21	22	22	23.5	21	19	23.2	21	19.4	21	22	22	23.5	21	19	23.2	21	19.4	23.9	22	20.2
Theoretical Shot Volume	cm <sup>3</sup>	653	778	913	848	995	1155	1181	1480	1813	1657	2029	2386	848	995	1155	1181	1480	1813	1657	2029	2386	2435	2863	3394
Shot Weight (PS)	g	594	707	830	771	905	1051	1074	1346	1649	1507	1846	2171	771	905	1051	1074	1346	1649	1507	1846	2171	2215	2605	3088
Injection Pressure	MPa	214	180	153	211	180	155	226	180	147	220	180	153	211	180	155	226	180	147	220	180	153	213	181	153
Holding Pressure	MPa	171	144	122	169	144	124	181	144	118	176	144	122	169	144	124	181	144	118	176	144	122	170	145	122
Injection Unit Model		1400h			1800h			2700h			3600h			1800h			2700h			3600h			5200		
Injection Rate	cm <sup>3</sup> /s	594	707	830	707	829	963	881	1104	1353	1105	1353	1591	707	829	963	881	1104	1353	1105	1353	1591	866	1018	1207
Injection Speed	mm/s	250	250	250	250	250	250	250	250	250	250	250	250	250	250	250	250	250	250	250	250	250	160	160	160
Injection Unit Model		1400			1800			2700			3600			1800			2700			3600			-		
Injection Rate	cm <sup>3</sup> /s	380	453	531	452	531	616	564	707	866	707	866	1018	452	531	616	564	707	866	707	866	1018	-	-	-
Injection Speed	mm/s	160	160	160	160	160	160	160	160	160	160	160	160	160	160	160	160	160	160	160	160	160	-	-	-
Injection Unit Model		1400hs			1800hs			-			-			1800hs			-			-			-		
Injection Rate	cm <sup>3</sup> /s	831	990	1162	989	1161	1348	-	-	-	-	-	-	989	1161	1348	-	-	-	-	-	-	-	-	-
Injection Speed	mm/s	350	350	350	350	350	350	-	-	-	-	-	-	350	350	350	-	-	-	-	-	-	-	-	-
Injection Stroke (Max.)	mm	275	275	275	300	300	300	335	335	335	375	375	375	300	300	300	335	335	335	375	375	375	450	450	450
Screw Speed (Max.)	rpm	300	300	300	250	250	250	250	250	250	230	230	230	250	250	250	250	250	250	230	230	230	230	230	230
Nozzle Contact Force (Max.)	kN	64	64	64	64	64	64	64	64	64	64	64	64	64	64	64	64	64	64	64	64	64	64	64	64
Nozzle Stroke (Max.)	mm	470	470	470	470	470	470	470	470	470	470	470	470	520	520	520	520	520	520	520	520	520	520	520	520
<b>Camping Unit</b>																									
Clamping Force	kN	4500												5500											
Mold Opening Stroke	mm	820												900											
Mold Dimensions	mm	1290x1290												1400x1400											
Space Between Tie Bars (HxV)	mm	920x920												980x980											
Mold Force (Min.-Max.)	mm	330-810												400~900											
Max. Daylight	mm	1630												1800											
Ejector Force	kN	98												154											
Ejector Stroke	mm	180												200											
No. of Ejector Pins	PCS	12+1												12+1											
Locating Ring Diameter	mm	200												200											
<b>Others</b>																									
Total Power Capacity	kW	1400:98kW			1800:101kW			2700:124kW			3600:160kW			1800:118kW			2700:141kW			3600:149kW			5200:152kW		
		1400h:98kW			1800h:101kW			2700h:124kW			3600h:160kW			1800h:118kW			2700h:141kW			3600h:149kW			-		
		1400hs:98kW			1800hs:103kW			-			-			1800hs:118kW			-			-			-		
Max. Rated Current	A	1400:172A			1800:178A			2700:219A			3600:282A			1800:208A			2700:248A			3600:262A			5200:268A		
		1400h:172A			1800h:178A			2700h:219A			3600h:282A			1800h:208A			2700h:248A			3600h:262A			-		
		1400hs:172A			1800hs:181A			-			-			1800hs:208A			-			-			-		
Heating Power	kW	24.0	26.8	36.1	26.8	36.1	38.8	34.4	34.4	34.4	39.6	39.6	39.6	26.8	36.1	38.8	34.4	34.4	34.4	39.6	39.6	39.6	48.5	48.5	48.5
Temperature Control Zone	Zone	4+1		5+1		4+1		5+1		5+1		5+1		4+1		5+1		5+1		5+1		6+1		6+1	
Machine Dimensions (LxWxH)	m	8.65x2.13x2.55			8.65x2.13x2.55			8.97x2.13x2.55			9.33x2.13x2.55			9.4x2.3x2.6			9.4x2.3x2.6			9.4x2.3x2.6			9.5x2.3x2.6		
Machine Weight	T	23.0			23.2			23.4			23.8			26.9			27.6			29.0			30.0		

\*To enhance the using experience, the company keeps upgrading the products and reserves the right to change the product specification and parameters without prior notice. The final interpretation to the above specification and parameters belongs to the company.

# SPARK AE | Specifications

Specifications	Unit	AE650								
Injection Unit		A	B	C	A	B	C	A	B	C
Screw Diameter	mm	67	75	83	75	83	90	83	90	98
Screw L/D Ratio	/	23.5	21	19	23.2	21	19.4	23.9	22	20.2
Theoretical Shot Volume	cm <sup>3</sup>	1181	1480	1813	1657	2029	2386	2435	2863	3394
Shot Weight (PS)	g	1074	1346	1649	1507	1846	2171	2215	2605	3088
Injection Pressure	MPa	226	180	147	220	180	153	213	181	153
Holding Pressure	MPa	181	144	118	176	144	122	170	145	122
Injection Unit Model		2700h			3600h			5200		
Injection Rate	cm <sup>3</sup> /s	881	1104	1353	1105	1353	1591	866	1018	1207
Injection Speed	mm/s	250	250	250	250	250	250	160	160	160
Injection Unit Model		2700			3600			-		
Injection Rate	cm <sup>3</sup> /s	564	707	866	707	866	1018	-	-	-
Injection Speed	mm/s	160	160	160	160	160	160	-	-	-
Injection Unit Model		-			-			-		
Injection Rate	cm <sup>3</sup> /s	-	-	-	-	-	-	-	-	-
Injection Speed	mm/s	-	-	-	-	-	-	-	-	-
Injection Stroke (Max.)	mm	335	335	335	375	375	375	450	450	450
Screw Speed (Max.)	rpm	250	250	250	230	230	230	230	230	230
Nozzle Contact Force (Max.)	kN	64	64	64	64	64	64	64	64	64
Nozzle Stroke (Max.)	mm	560	560	560	560	560	560	560	560	560
<b>Clamping Unit</b>										
Clamping Force	kN	6500								
Mold Opening Stroke	mm	1000								
Mold Dimensions	mm	1560x1560								
Space Between Tie Bars (HxV)	mm	1090X1090								
Mold Force (Min.-Max.)	mm	420~1000								
Max. Daylight	mm	2000								
Ejector Force	kN	220								
Ejector Stroke	mm	200								
No. of Ejector Pins	PCS	12+1								
Locating Ring Diameter	mm	200								
<b>Others</b>										
Total Power Capacity	kW	2700: 149kW			3600: 156kW			5200: 159W		
		2700h: 149kW			3600h: 156kW			-		
		-			-			-		
Max. Rated Current	A	2700: 261A			3600: 275A			5200: 281A		
		2700h: 261A			3600h: 275A			-		
		-			-			-		
Heating Power	kW	34.4	34.4	34.4	39.6	39.6	39.6	48.5	48.5	48.5
Temperature Control Zone	Zone	5+1			5+1			6+1		
Machine Dimensions (LxWxH)	m	10.2x2.5x2.65			10.3x2.5x2.65			10.3x2.5x2.65		
Machine Weight	T	34.8			35.3			36.3		

\*To enhance the using experience, the company keeps upgrading the products and reserves the right to change the product specification and parameters without prior notice. The final interpretation to the above specification and parameters belongs to the company.

## SPARK AE All-Electric 20-650T



\* The above product pictures are for reference only. Please refer to actual product drawings.

# SPARK AE | Features

P.S. ●Standard, ○Optional, ✕Not Available, Numbers indicate required quantities.

	CONFIGURATIONS	SPARK AE
INJECTION UNIT	1. Ceramic Heater Band	●
	2. Infrared Heater Band	○
	3. Barrel Insulation Cover	○
	4. Insulated Barrel Guard	●
	5. Wear-Resistant Screw and Barrel Unit	●
	6. Bimetallic Screw and Barrel	○
	7. Bimetallic Screw and Barrel Set	○
	8. Special Screw and Barrel Set For PEF/PVC	○
	9. Custom Screw and Nozzle	○
	10. Shot-Off Nozzle	○
	11. Carriage Linear Transducer	○
	12. Screw RPM Display	●
	13. Barrel Cooling Control	●
	14. Simultaneous Plasticising	●
	15. Automatic PID Temperature Control	●
	16. Proportional Back Pressure	●
	17. Thermocouple Open Circuit Detection	●
	18. Nozzle Blockage and Overflow Detection	●
	19. Locking Type Screw Tip Set	○
	20. Hydraulic/Pneumatic Sequential Injection	○
	21. Dual Injection	●
	22. Low Pressure Injection	●
	23. Linear Rail	●
	24. Injection Compression Molding	●
	25. Barrel Inlet Cooling Water Automatic Control	●
	26. Spray Painting Hopper	○
	27. Color Masterbatch Feeder Interface	○
	28. Smaller/Larger Injection Unit	○

	CONFIGURATIONS	SPARK AE
CLAMPING UNIT	1. Eurmap 2	○
	2. Fully Automatic Intelligent Distribution Centralized Lubrication System	●
	3. Core Pull One Set	○
	4. Multiple Core Pull (Hydraulic/ Pneumatic)	○
	5. One Set of Air Blowing for the First and Second Platens Each	●
	6. Multiple Air Blow	○
	7. Product Chute	○
	8. High-Spend Clamping Force	●
	9. High-Precision Chrome-Plated Tie Bar	●
	10. Auto-Front Door	○
	11. Auto-Clamping Force Control	●
	12. Safety Door Electromagnetic Locking Device	●
	13. Ejector On the Fly	●
	14. In-Mold Ejector	●
	15. Dual Ejector	●
	16. Centre Ejector Rod Reverse Pull Mechanism	●
	17. Clamping Unit Linear Guide	●
	18. Custom Mold	○
	19. Hot Runner Pin	○

	CONFIGURATIONS	SPARK AE
CONTROL UNIT	1. CHE Controller	●
	2. 15"HD TF Touch-Screen Display	●
	3. International Units (Metric/Imperial Freely Switchable)	●
	4. High Dynamic Response Safety Servo Assembly Compliant With STO Standards	●
	5. High-Precision Mold Safety	●
	6. High-Speed Control base on EtherCAT	●
	7. Euromap 12 Robot Interface	○
	8. Euromap 67 Robot Interface	○
	9. Euromap 18 Robot Interface	○
	10. Euromap 13 Coll Pull/Ejector Signal Interface	○
	11. Euromap 70 and 70.1	○
	12. USB Interface	●
	13. OPC--UA	●
	14. Free I/O Board	●
	15. LED Back Light	●
	16. Three Color LED Alarm Light	●
	17. Variable Servo Rigidity System	●
	18. Solid State Relay	●
	19. Robot Interface (Non-European)	●
	20. Magnetic (Hydraulic) Mold Clamp System Interface	○
	21. Sequential/Hydraulic/Electric Unscrewing	○
	22. Gas-Assisted Control Electrical Interface	○
	23. Heater Break Detection	○
	24. Energy-Saving Heating System	○
	25. Micro-Foaming Control System Interface	○
	26. Hot Runner Control System	○

	CONFIGURATIONS	SPARK AE
OTHERS	1. Three-Phase 380V 32A Power Supplies - Two Sets Single-Phase 220V 32A Power Supply - One Set Single-Phase 220V 10A Power Supply - One Set	20 - 360T
	2. Three-Phase 380V 32A Power Supplies - Two Sets Three-Phase 380V 32A Power Supplies - One Set Single-Phase 220V 10A Power Supply - One Set	450 - 650T
	3. D10 Quick Connector Mold Cooling Water - 5 Sets	20 - 180T
	4. D10 Quick Connector Mold Cooling Water - 7 Sets	230 - 650T



\*To enhance the using experience, the company keeps upgrading the products and reserves the right to change the product specification and parameters without prior notice. The final interpretation to the above specification and parameters belongs to the company.



# SPARK AE | Mold and Machine Dimensions

## AE60

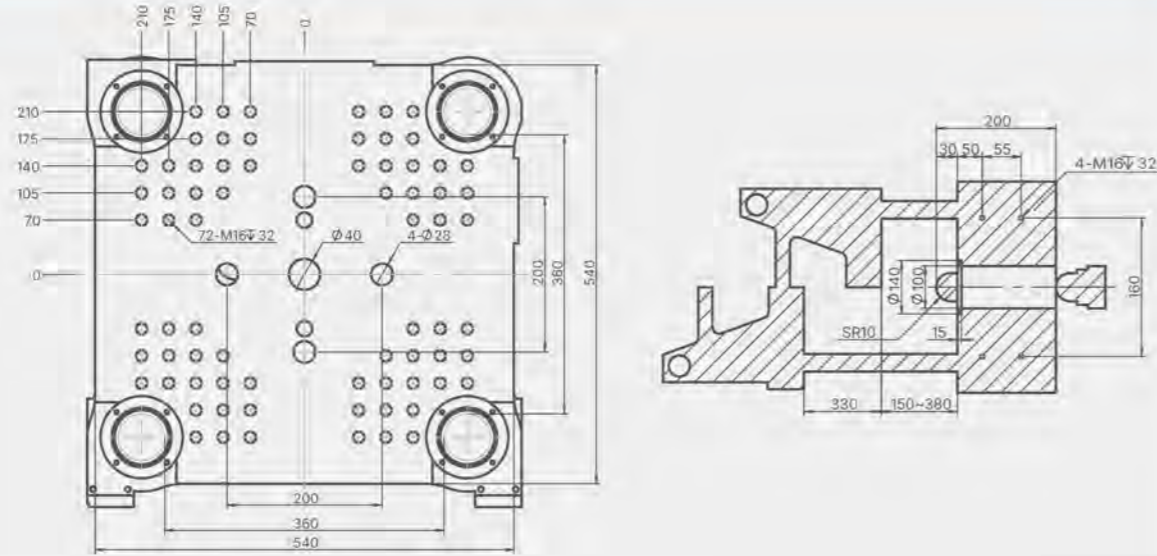

Machine Dimensions (LxWxH)

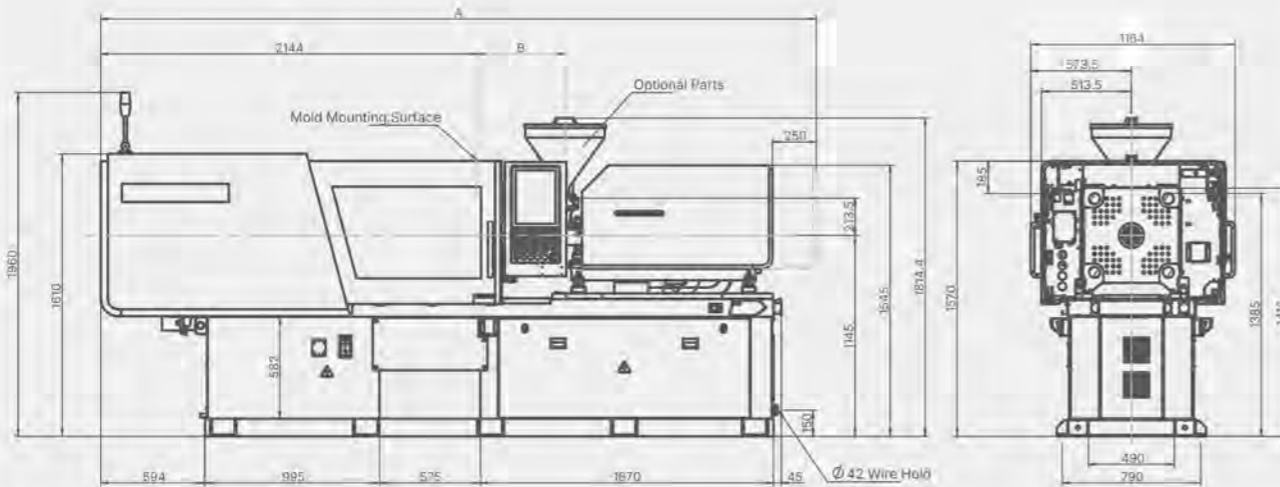

## AE100

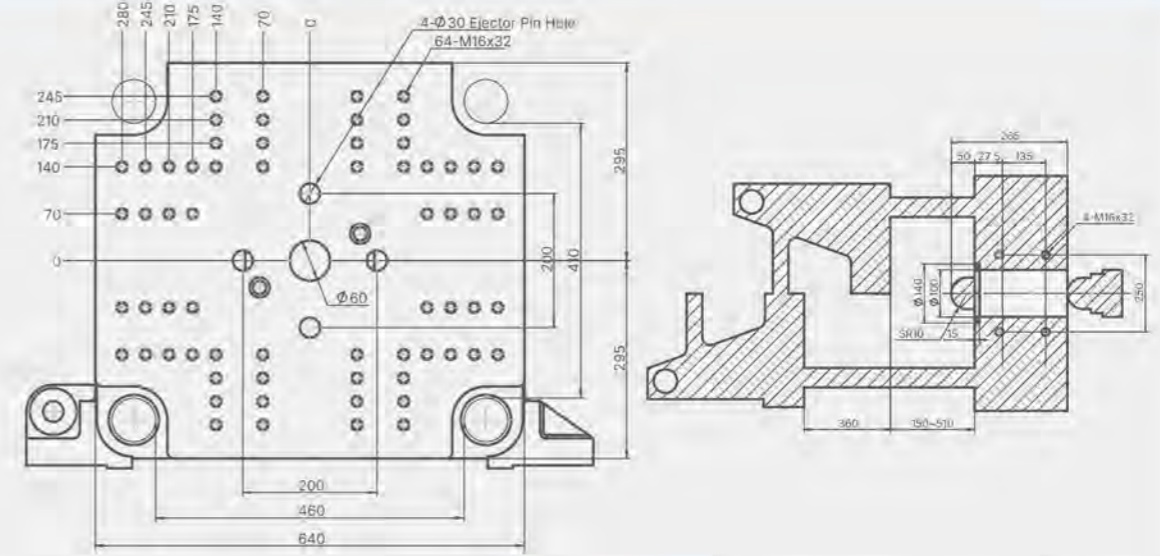

Machine Dimensions (LxWxH)

Injection Unit Model	A	B	C	D	E
110	4563	485	1570	1800	165
160	4662	708	1605	1828	184
210	4812	858	1605	1820	172

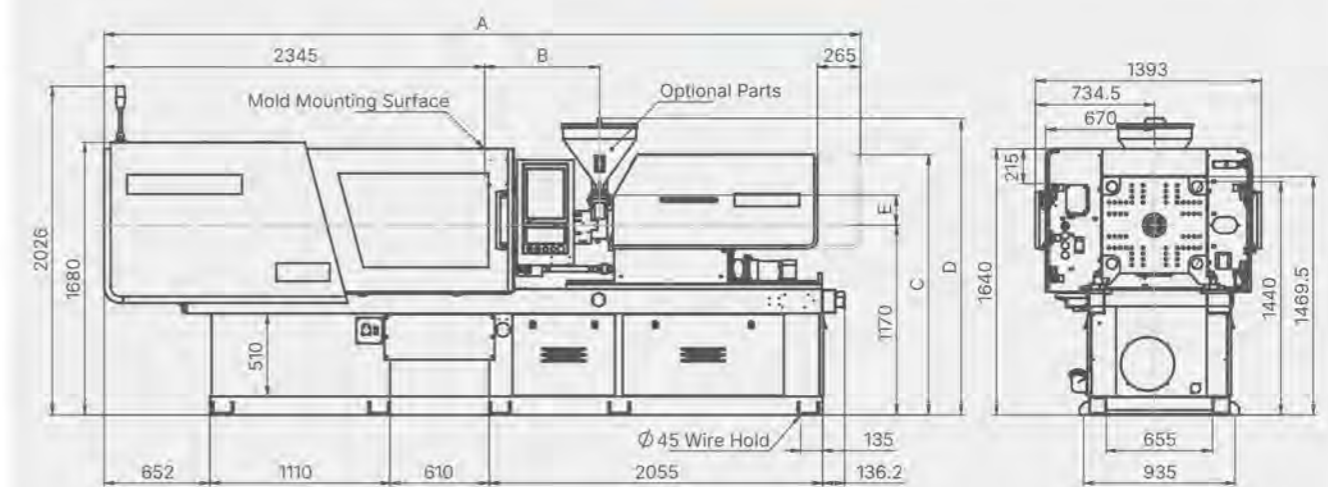

\*To enhance the using experience, the company keeps upgrading the products and reserves the right to change the product specification and parameters without prior notice. The final interpretation to the above specification and parameters belongs to the company.

# SPARK AE | Mold and Machine Dimensions

## AE120

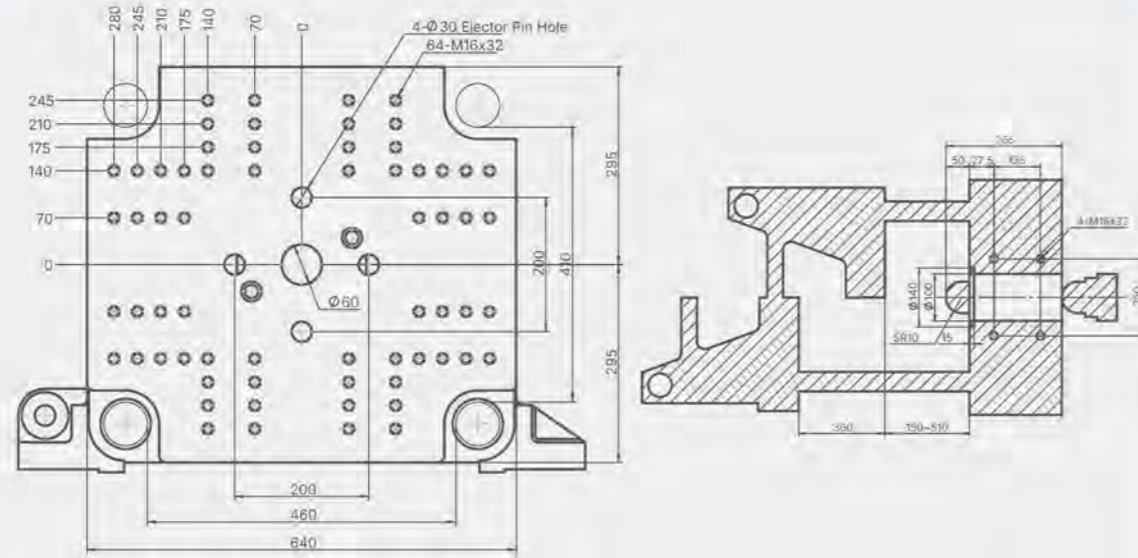

Machine Dimensions (LxWxH)

Injection Unit Model	A	B	C	D	E
160	4662	708	1605	1828	184
210	4812	858	1605	1820	172
330	5140	887	1660	1848	210
450	5344	1091	1660	1853	215

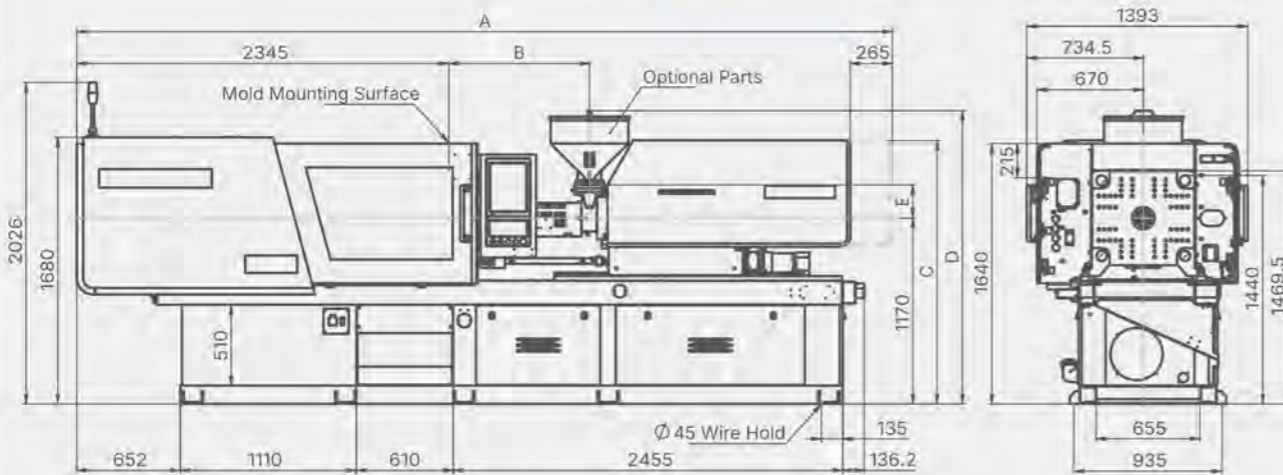

\*To enhance the using experience, the company keeps upgrading the products and reserves the right to change the product specification and parameters without prior notice. The final interpretation to the above specification and parameters belongs to the company.

## AE150

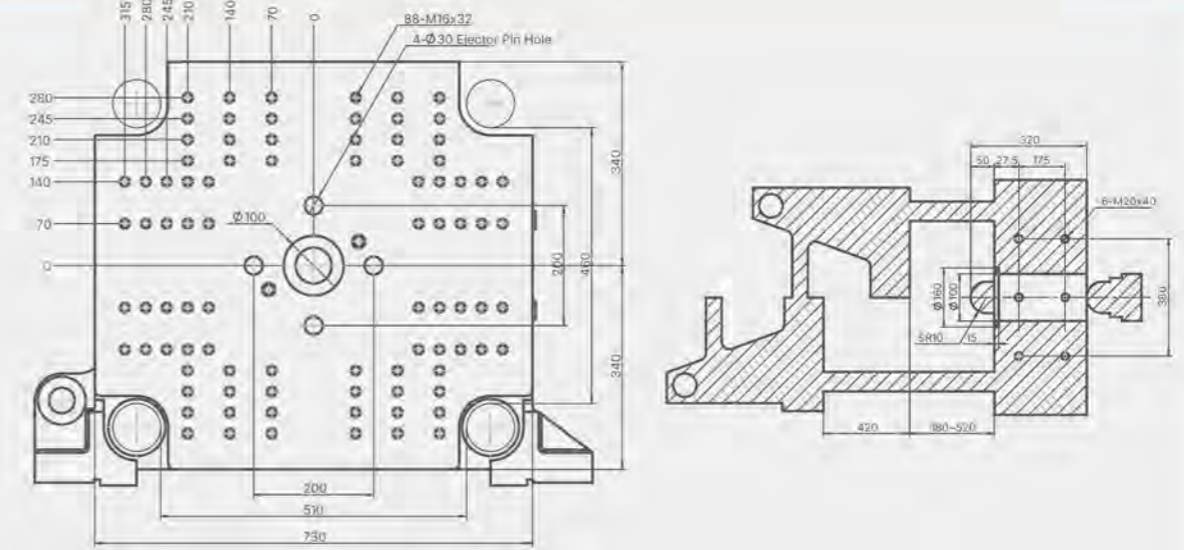

Machine Dimensions (LxWxH)

Injection Unit Model	A	B	C	D	E
210	5406	797	1580.5	1729	172
330	5735	887	1633.5	1772	215
450	5938	981	1635	1772	215
640	6156	1091	1640.5	1772	215

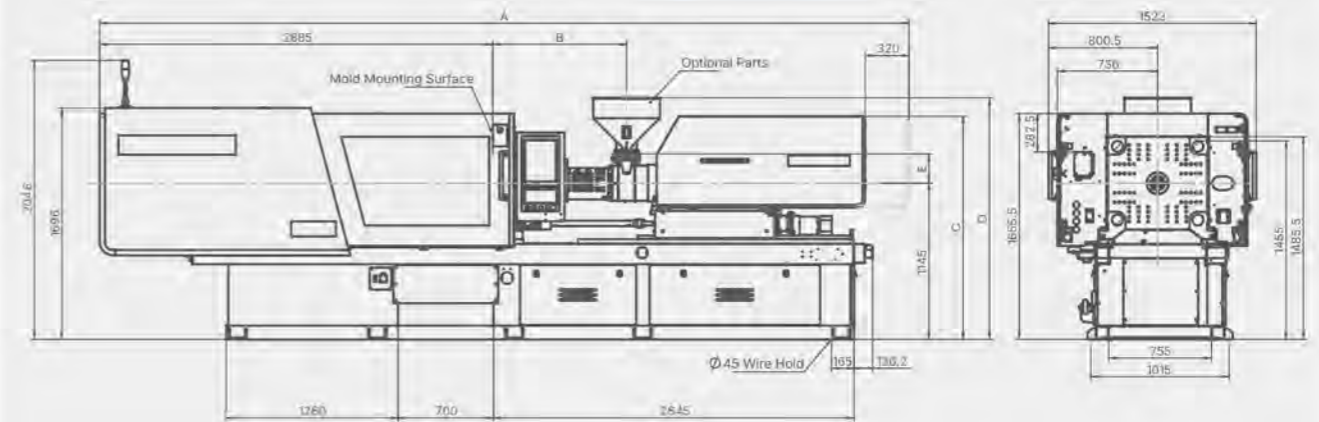

# SPARK AE | Mold and Machine Dimensions

## AE180

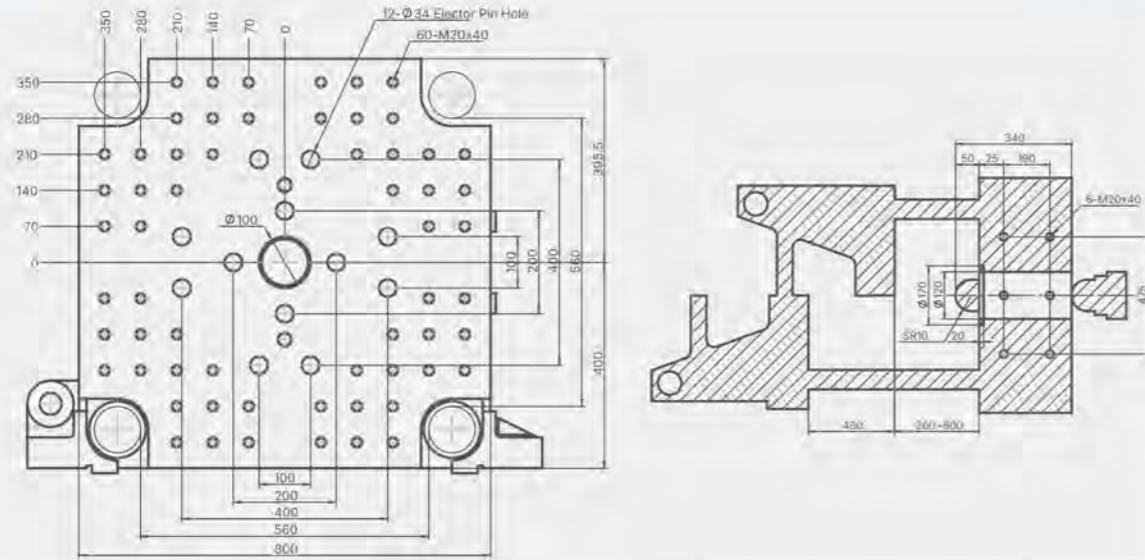

Machine Dimensions (LxWxH)

Injection Unit Model	A	B	C	D	E
330	6015	887	1715.5	1847	210
450	6219	982	1715.5	1852	215
640	6437	1092	1720.5	1852	215
890	6750	1202	1835.5	2031	217

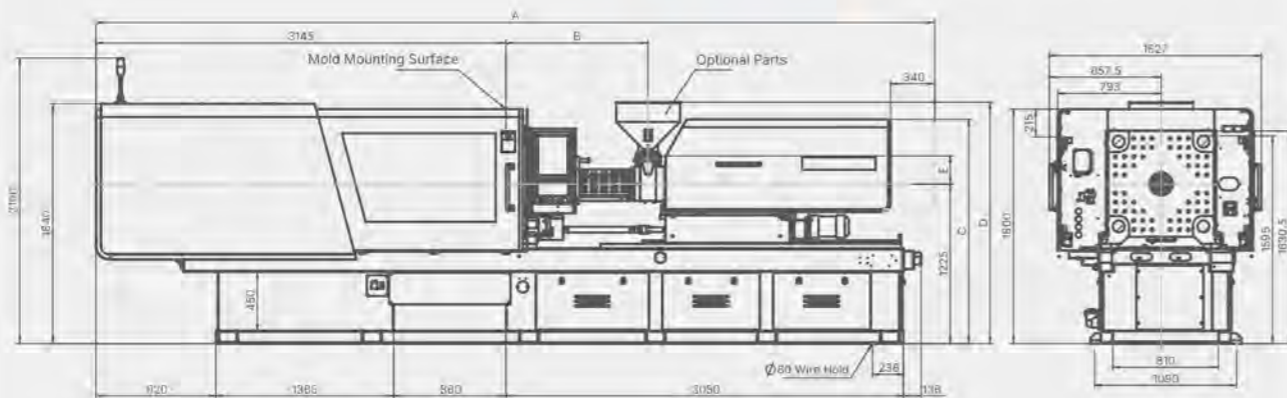

## AE230

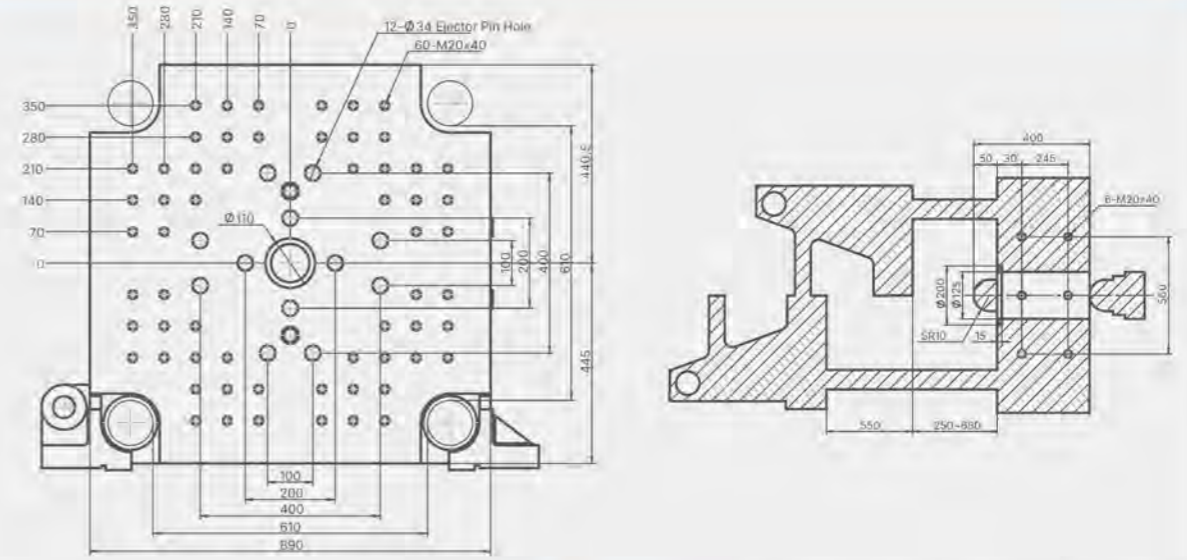

Machine Dimensions (LxWxH)

Injection Unit Model	A	B	C	D	E
450	6607.5	982	1790.5	1927.5	215
640	6825	1092	1795.5	1927.5	215
890	7138.5	1202	1910.5	2106.5	217
1100	7368.5	1332	1910.5	2106.5	217

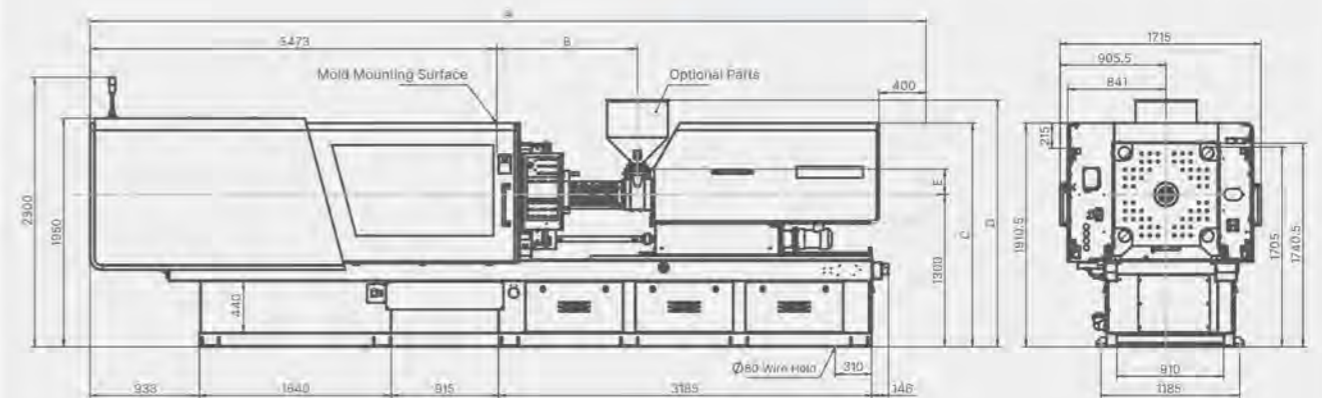

\*To enhance the using experience, the company keeps upgrading the products and reserves the right to change the product specification and parameters without prior notice. The final interpretation to the above specification and parameters belongs to the company.

# SPARK AE | Mold and Machine Dimensions

## AE300

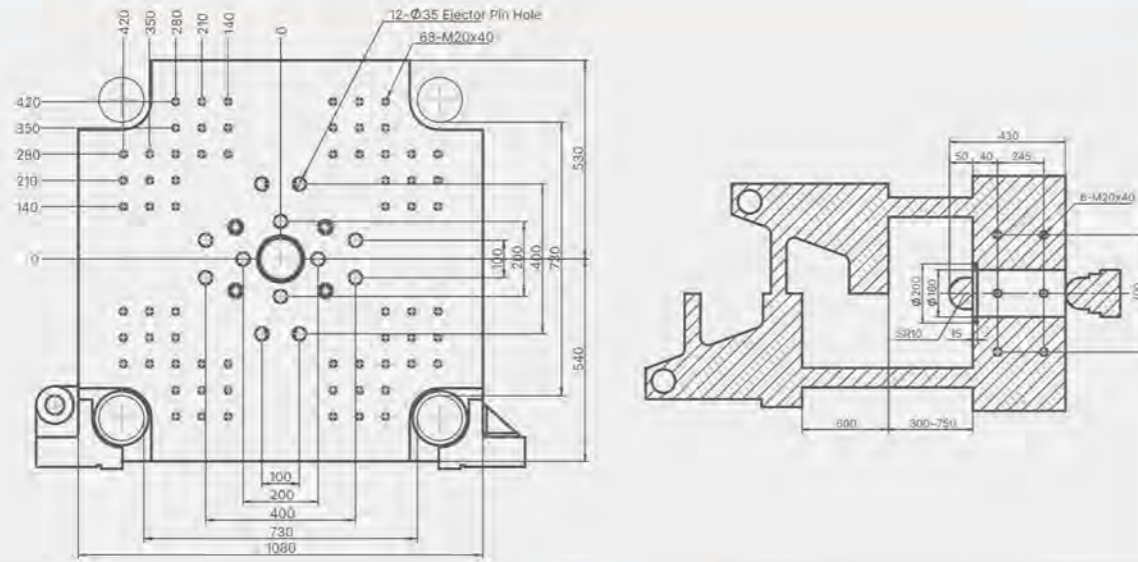

Machine Dimensions (LxWxH)

Injection Unit Model	A	B	C	D	E
890	7645	1202	2001	2197	217
1100	7775	1332	2001	2197	217
1400	8130	1452	2046	2197	217
1800	8309	1631	2046	2197	217

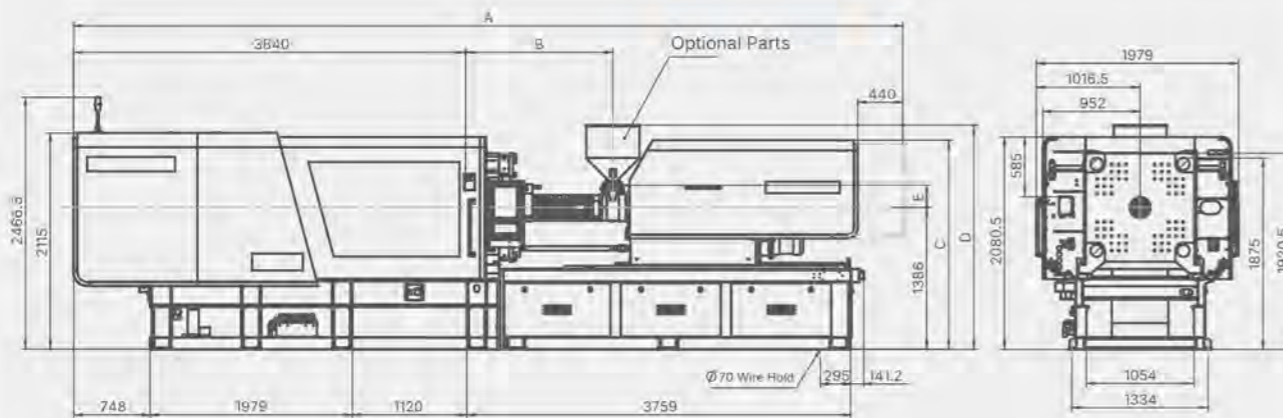

## AE360

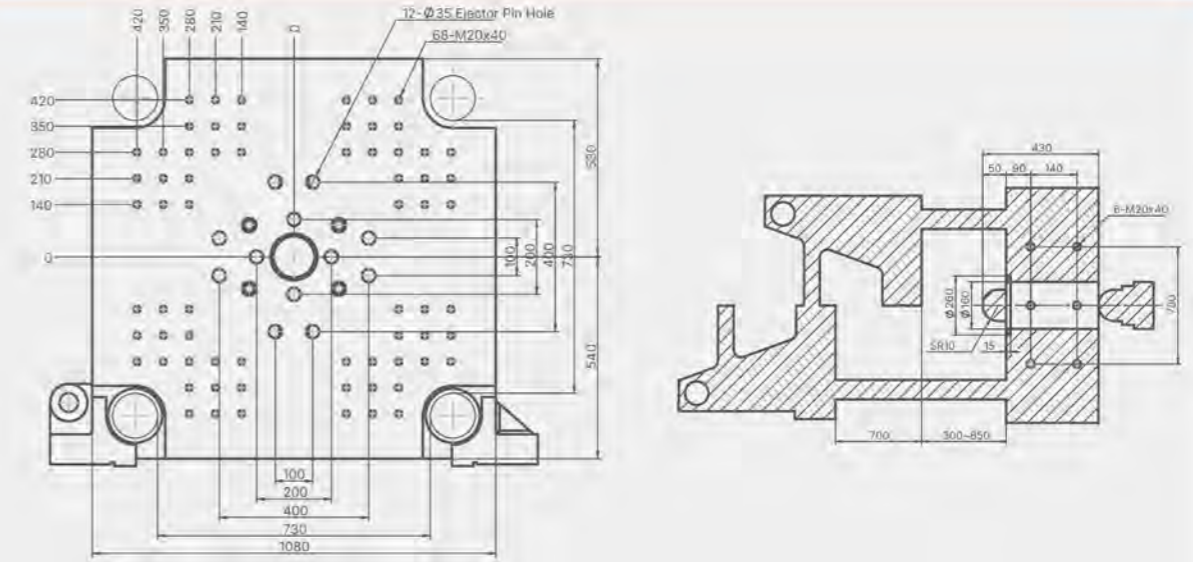

Machine Dimensions (LxWxH)

Injection Unit Model	A	B	C	D	E
1110	8175	1332	1961	2161.5	217
1400	8530	1452	2055	2201.5	217
1800	8819	1631	2055	2201.5	217
2700	9301	1825	2117.5	2231.5	247

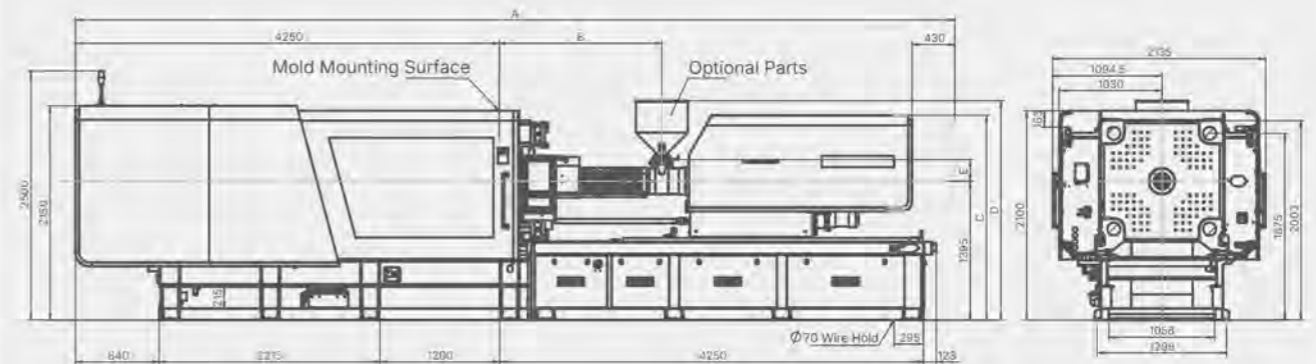

\*To enhance the using experience, the company keeps upgrading the products and reserves the right to change the product specification and parameters without prior notice. The final interpretation to the above specification and parameters belongs to the company.

# SPARK AE | Mold and Machine Dimensions

## AE450

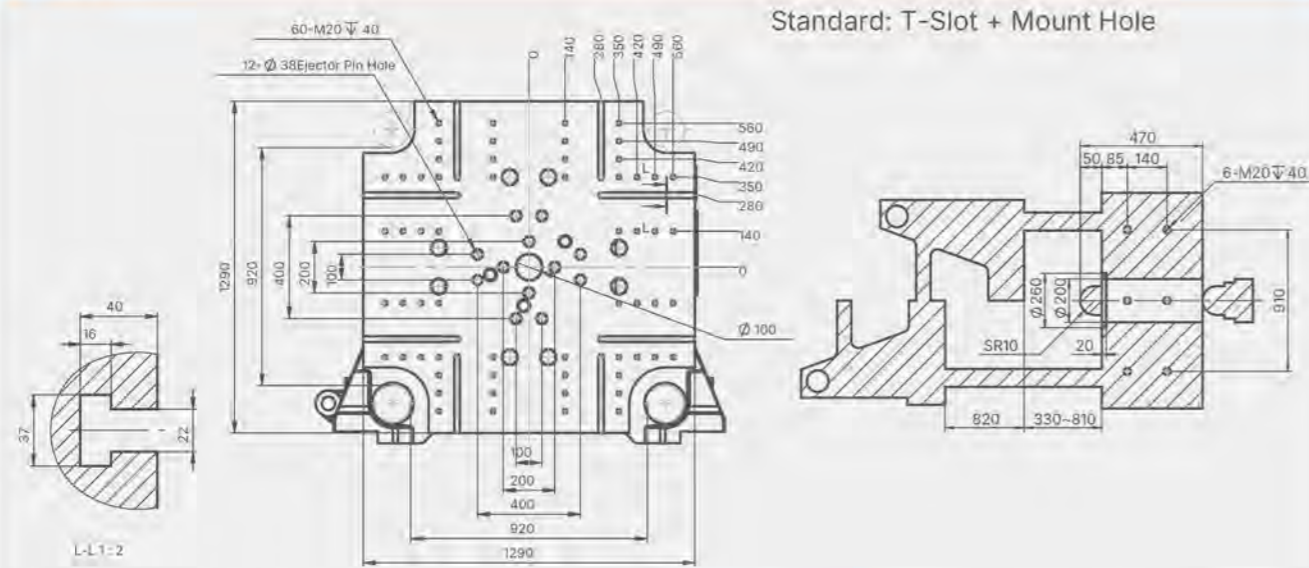

Standard: T-Slot + Mount Hole

Machine Dimensions (LxWxH)

Injection Unit Model	A	B	C	D	E
1400	8351	1452	2156	2307	217
1800	8641	1631	2156	2307	217
2700	8973	1825	2223	2337	247
3600	9335	2039	2370	2497	408

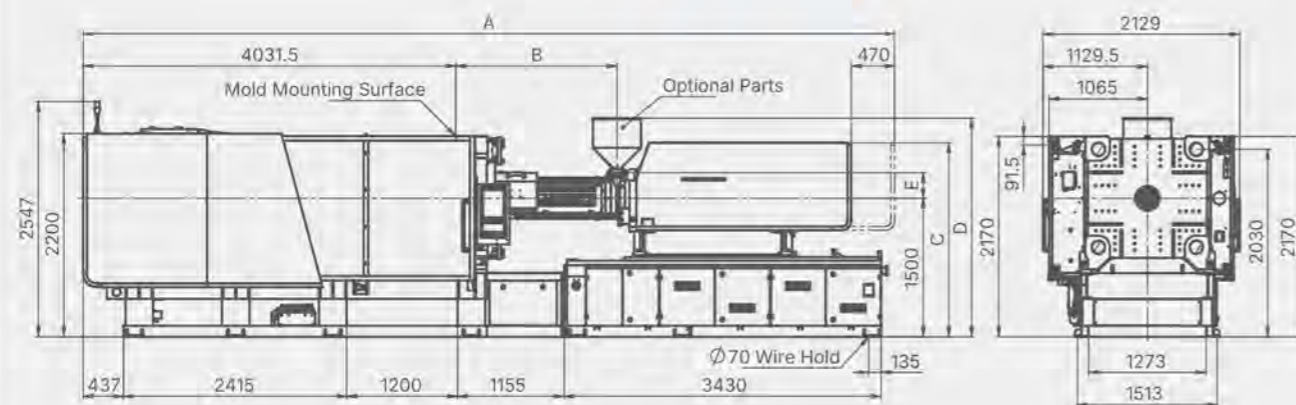

## AE550

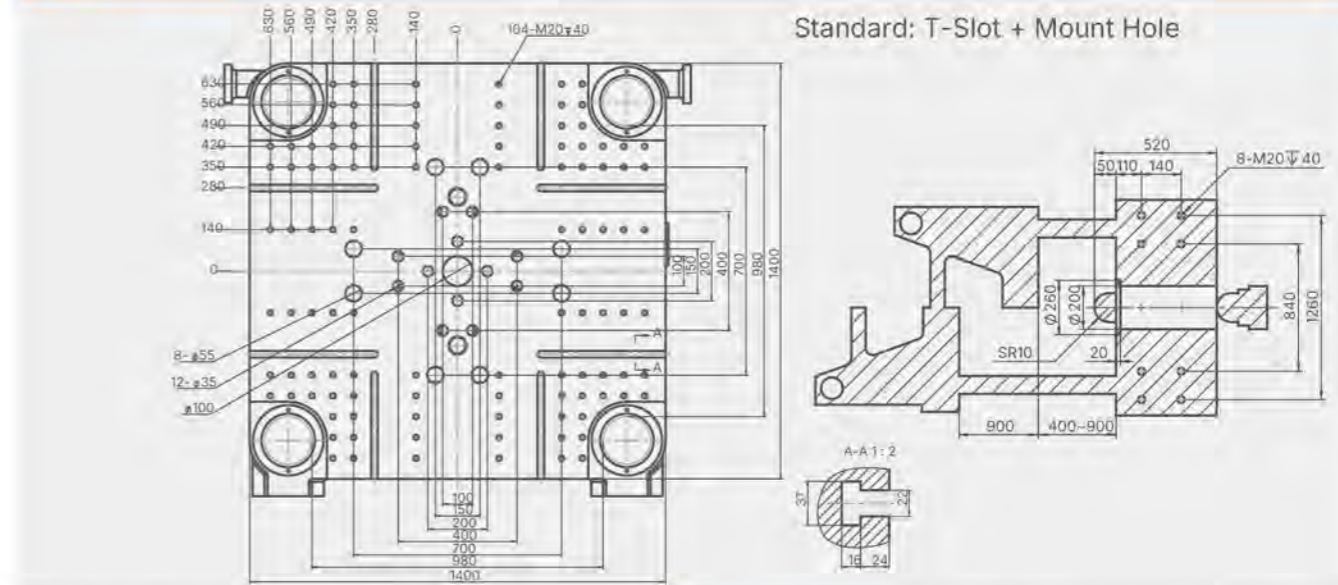

Standard: T-Slot + Mount Hole

Machine Dimensions (LxWxH)

Injection Unit Model	A	B	C	D	E
1800	8706	1651	2136	2287	217
2700	9038	1825	2203	2317	247
3600	9400	2039	2350	2477	408
5200	9500	2291	2350	2477	408

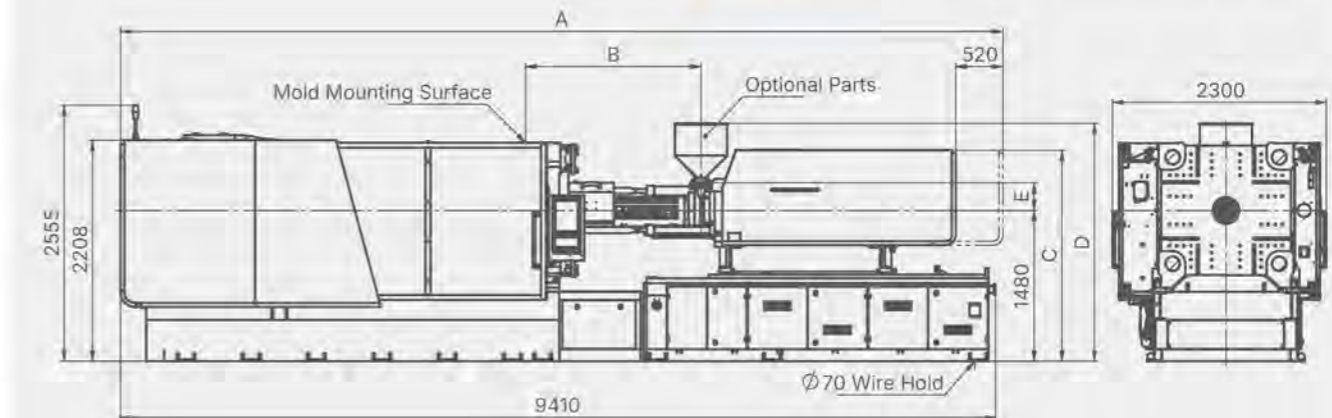

\*To enhance the using experience, the company keeps upgrading the products and reserves the right to change the product specification and parameters without prior notice. The final interpretation to the above specification and parameters belongs to the company.

# SPARK AE | Mold and Machine Dimensions

## AE650

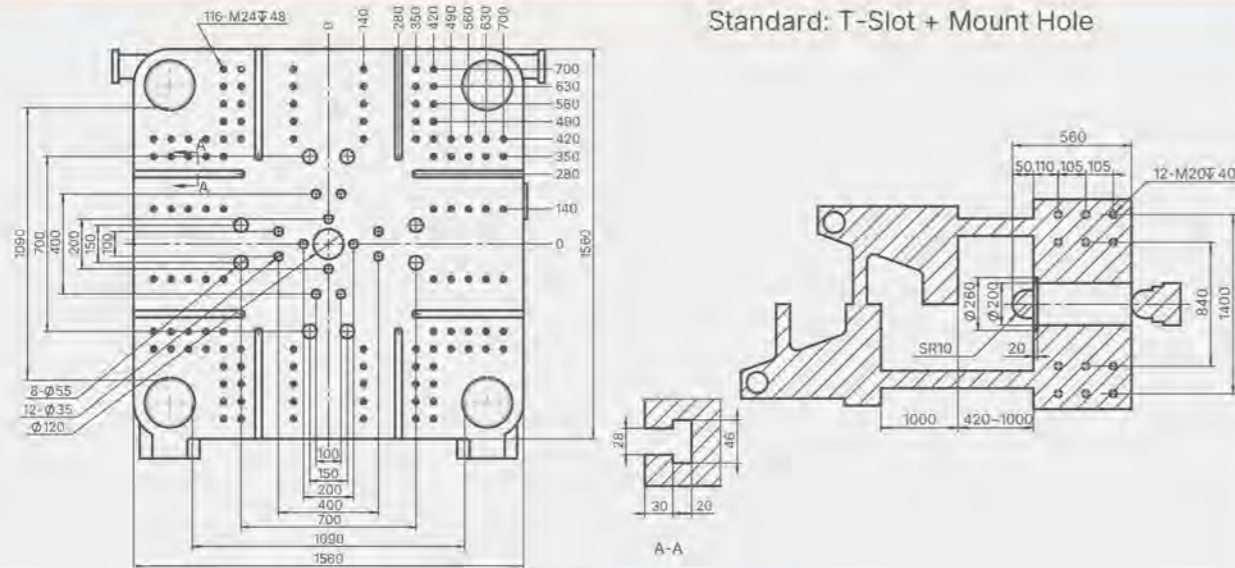

Standard: T-Slot + Mount Hole

Machine Dimensions (LxWxH)

Injection Unit Model	A	B	C	D	E
2700	10100	1825	2228	2342	247
3600	10268	2039	2375	2502	408
5200	10520	2291	2375	2502	408

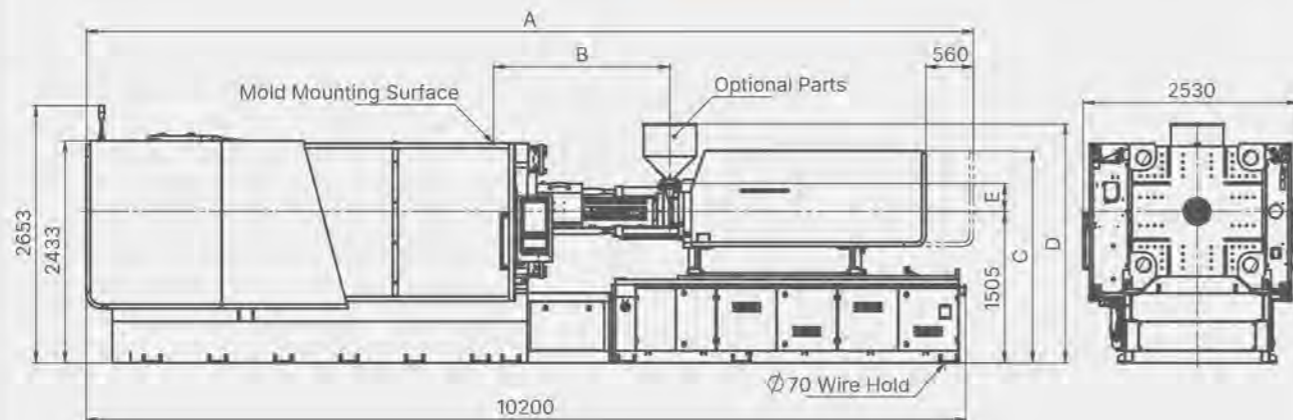

\*To enhance the using experience, the company keeps upgrading the products and reserves the right to change the product specification and parameters without prior notice. The final interpretation to the above specification and parameters belongs to the company.

# SPARK AE | Optional: T-Slot + Mount Hole Mold Platen

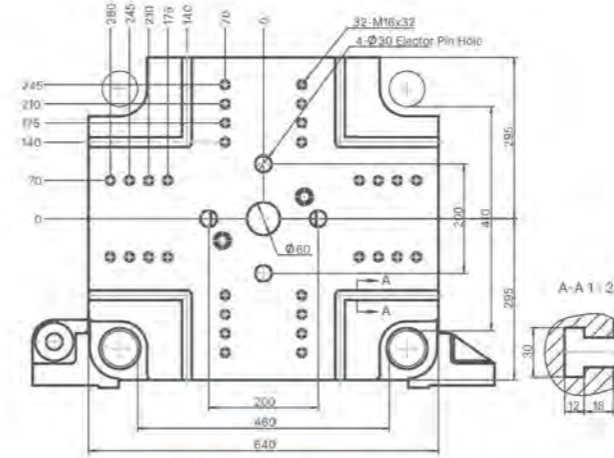

AE100-AE120

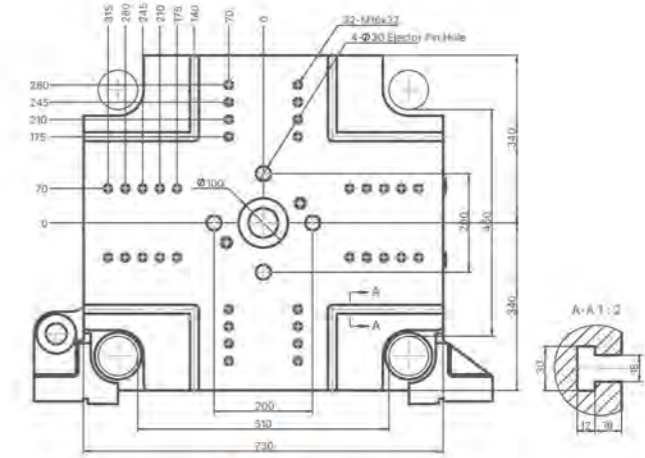

AE150

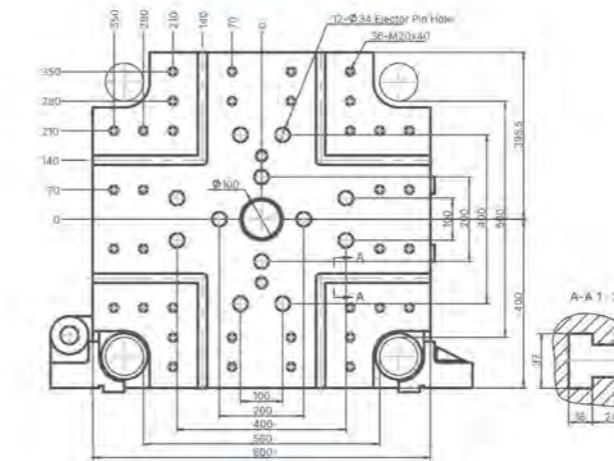

AE180

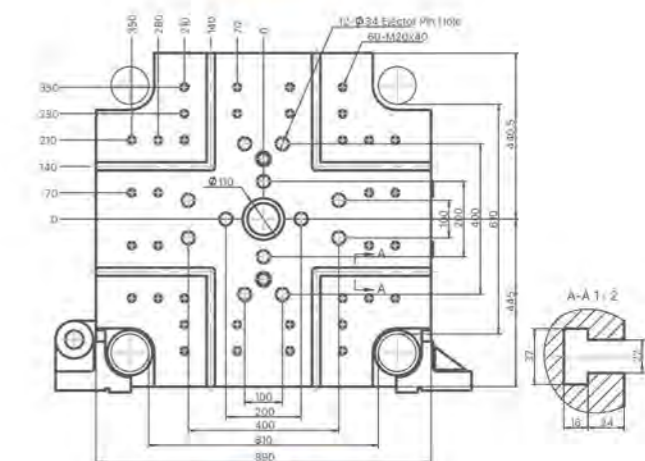

AE230

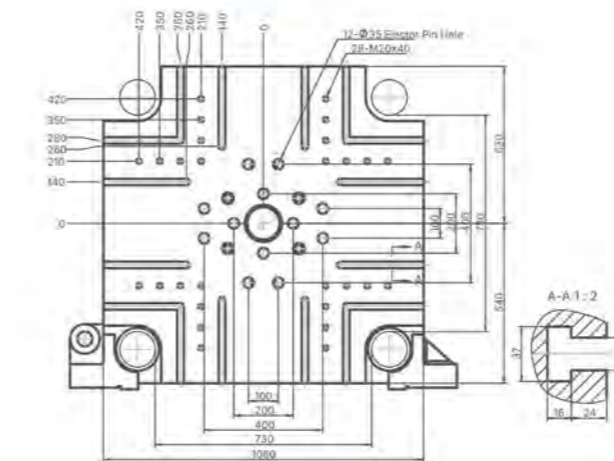

AE300

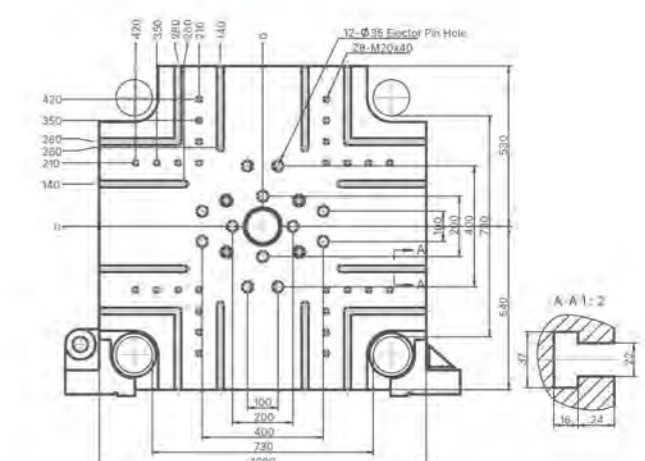

AE360

# SPARK EH | Specifications

Specifications	Unit	EH100									EH120														
Injection Unit		A	B	C	A2	A1	A	B	C	A	B	C	A2	A1	A	B	C	A1	A	B	C	A	B	C	
Screw Diameter	mm	26	28	30	26	28	30	32	36	26	28	30	26	28	30	32	36	30	32	36	40	36	40	45	
Screw L/D Ratio	/	21	21	21	21	21	21	21	21	21	21	21	21	21	21	21	21	21	21	21	21	21	21	21	
Theoretical Shot Volume	cm <sup>3</sup>	62	72	83	62	78	89	101	128	62	72	83	62	78	89	101	128	106	129	163	201	183	226	286	
Shot Weight (PS)	g	56	65	75	56	70	80	91	116	56	65	75	56	70	80	91	116	96	117	148	182	166	205	260	
Injection Pressure	MPa	255	220	192	303	261	228	200	158	255	220	192	303	261	228	200	158	288	253	200	162	247	200	158	
Holding Pressure	MPa	204	176	154	242	209	182	160	126	204	176	154	242	209	182	160	126	230	202	160	130	198	160	126	
Injection Unit Model		160			210			160			210			330			450								
Injection Rate	cm <sup>3</sup> /s	106	123	142	106	124	141	160	203	106	123	142	106	124	141	160	203	141	161	204	251	203	251	318	
Injection Speed	mm/s	200	200	200	200	200	200	200	200	200	200	200	200	200	200	200	200	200	200	200	200	200	200	200	
Injection Unit Model		160h			210h			160h			210h			330h			450h								
Injection Rate	cm <sup>3</sup> /s	185	215	248	185	217	247	281	356	185	215	248	185	217	247	281	356	247	282	357	440	305	377	477	
Injection Speed	mm/s	350	350	350	350	350	350	350	350	350	350	350	350	350	350	350	350	350	350	350	350	300	300	300	
Injection Unit Model		160hs			210hs			160hs			210hs			330hs			450hs								
Injection Rate	cm <sup>3</sup> /s	265	308	355	265	310	353	401	508	265	308	355	265	310	353	401	508	353	403	509	628	508	628	794	
Injection Speed	mm/s	500	500	500	500	500	500	500	500	500	500	500	500	500	500	500	500	500	500	500	500	500	500	500	
Injection Stroke (Max.)	mm	117	117	117	117	126	126	126	126	117	117	117	117	126	126	126	126	150	160	160	160	180	180	180	
Screw Speed (Max.)	rpm	400	400	400	400	400	400	400	400	400	400	400	400	400	400	400	400	400	400	400	400	400	400	400	
Nozzle Contact Force (Max.)	kN	33	33	33	33	33	33	33	33	33	33	33	33	33	33	33	33	62	62	62	62	62	62	62	
Nozzle Stroke (Max.)	mm	265	265	265	265	265	265	265	265	265	265	265	265	265	265	265	265	265	265	265	265	265	265	265	
<b>Camping Unit</b>																									
Clamping Force	kN	1000									1200														
Mold Opening Stroke	mm	360									360														
Mold Dimensions	mm	640x590									640x590														
Space Between Tie Bars (HxV)	mm	460x410									460x410														
Mold Force (Min.-Max.)	mm	150-510									150-510														
Max. Daylight	mm	870									870														
Ejector Force	kN	34									34														
Ejector Stroke	mm	100									100														
No. of Ejector Pins	PCS	4+1									4+1														
Locating Ring Diameter	mm	100									100														
<b>Others</b>																									
Total Power Capacity	kW	160: 17kW			210: 23kW			160: 17kW			210: 23kW			330: 25kW			450: 31kW								
		160h: 24kW			210h: 27kW			160h: 24kW			210h: 27kW			330h: 33kW			450h: 39kW								
		160hs: 32kW			210hs: 39kW			160hs: 32kW			210hs: 39kW			330hs: 49kW			450hs: 60kW								
Max. Rated Current	A	160: 31A			210: 41A			160: 31A			210: 41A			330: 45A			450: 56A								
		160h: 42A			210h: 49A			160h: 42A			210h: 49A			330h: 59A			450h: 69A								
		160hs: 56A			210hs: 69A			160hs: 56A			210hs: 69A			330hs: 87A			450hs: 106A								
Heating Power	kW	7.8	8.4	9.0	8.1	8.4	9.0	9.6	12.5	7.8	8.4	9.0	8.1	8.4	9.0	9.6	12.5	9.0	9.6	12.5	14.3	12.5	14.3	16.5	
Temperature Control Zone	Zone	3+1			3+1			4+1			3+1			3+1			4+1			4+1					
Max. System Pressure	MPa	17.5			17.5			17.5			17.5			17.5			17.5								
Oil Tank Capacity	L	60			60			60			60			60			60								
Machine Dimensions (LxWxH)	m	4.66x1.40x2.03			4.81x1.40x2.03			4.96x1.40x2.03			4.96x1.40x2.03			5.14x1.40x2.03			5.34x1.40x2.03								
Machine Weight	T	3.9			4.1			3.9			4.1			4.2			4.3								

\*To enhance the using experience, the company keeps upgrading the products and reserves the right to change the product specification and parameters without prior notice. The final interpretation to the above specification and parameters belongs to the company.

# SPARK EH | Specifications

Specifications	Unit	EH150															EH180																								
Injection Unit		A2	A1	A	B	C	A1	A	B	C	A	B	C	A	B	C	A1	A	B	C	A	B	C	A	B	C	A	B	C												
Screw Diameter	mm	26	28	30	32	36	30	32	36	40	36	40	45	40	45	50	30	32	36	40	36	40	45	40	45	50	45	50	55												
Screw L/D Ratio	/	21	21	21	21	21	21	21	21	21	21	21	21	21	21	21	21	21	21	21	21	21	21	21	21	21	21	21	21												
Theoretical Shot Volume	cm <sup>3</sup>	62	78	89	101	128	106	129	163	201	183	226	286	251	318	393	106	129	163	201	183	226	286	251	318	393	358	442	535												
Shot Weight (PS)	g	56	70	80	91	116	96	117	148	182	166	205	260	228	289	357	96	117	148	182	166	205	260	228	289	357	325	402	486												
Injection Pressure	MPa	303	261	228	200	158	288	253	200	162	247	200	158	253	200	162	288	253	200	162	247	200	158	253	200	162	247	200	165												
Holding Pressure	MPa	242	209	182	160	126	230	202	160	130	198	160	126	202	160	130	230	202	160	130	198	160	126	202	160	130	198	160	132												
Injection Unit Model		210					330					450					640					330					450					640					890				
Injection Rate	cm <sup>3</sup> /s	106	124	141	160	203	141	161	204	251	203	251	318	201	254	314	141	161	204	251	203	251	318	201	254	314	255	314	380												
Injection Speed	mm/s	200	200	200	200	200	200	200	200	200	200	200	200	160	160	160	200	200	200	200	200	200	200	160	160	160	160	160	160												
Injection Unit Model		210h					330h					450h					640h					330h					450h					640h					890h				
Injection Rate	cm <sup>3</sup> /s	185	217	247	281	356	247	282	357	440	305	377	477	314	398	491	247	282	357	440	305	377	477	314	398	491	398	491	594												
Injection Speed	mm/s	350	350	350	350	350	350	350	350	350	300	300	300	250	250	250	350	350	350	350	300	300	300	250	250	250	250	250	250												
Injection Unit Model		210hs					330hs					450hs					640hs					330hs					450hs					640hs					890hs				
Injection Rate	cm <sup>3</sup> /s	265	310	353	401	508	353	403	509	628	508	628	794	439	557	688	353	403	509	628	508	628	794	439	557	688	557	688	832												
Injection Speed	mm/s	500	500	500	500	500	500	500	500	500	500	500	500	350	350	350	500	500	500	500	500	500	500	350	350	350	350	350	350												
Injection Stroke (Max.)	mm	117	126	126	126	126	150	160	160	160	180	180	180	200	200	200	150	160	160	160	180	180	180	200	200	200	225	225	225												
Screw Speed (Max.)	rpm	400	400	400	400	400	400	400	400	400	400	400	400	350	350	350	400	400	400	400	400	400	400	350	350	350	320	320	320												
Nozzle Contact Force (Max.)	kN	33	33	33	33	33	62	62	62	62	62	62	62	62	62	62	62	62	62	62	62	62	62	62	62	62	62	91	91	91											
Nozzle Stroke (Max.)	mm	320	320	320	320	320	320	320	320	320	320	320	320	320	320	320	340	340	340	340	340	340	340	340	340	340	340	340	340												
<b>Camping Unit</b>																																									
Clamping Force	kN	1500														1800																									
Mold Opening Stroke	mm	420														480																									
Mold Dimensions	mm	730x680														800x795.5																									
Space Between Tie Bars (HxV)	mm	510x460														560x560																									
Mold Force (Min.-Max.)	mm	180-520														200-600																									
Max. Daylight	mm	940														1080																									
Ejector Force	kN	34														67																									
Ejector Stroke	mm	120														120																									
No. of Ejector Pins	PCS	4+1														12+1																									
Locating Ring Diameter	mm	100														120																									
<b>Others</b>																																									
Total Power Capacity	kW	210: 32kW					330: 33kW					450: 40kW					640: 44kW					330: 33kW					450: 40kW					640: 44kW					890: 48kW				
		210h: 32kW					330h: 33kW					450h: 40kW					640h: 44kW					330h: 33kW					450h: 40kW					640h: 44kW					890h: 48kW				
		210hs: 39kW					330hs: 49kW					450hs: 60kW					640hs: 61kW					330hs: 49kW					450hs: 60kW					640hs: 61kW					890hs: 67kW				
Max. Rated Current	A	210: 57A					330: 59A					450: 71A					640: 77A					330: 59A					450: 71A					640: 77A					890: 85A				
		210h: 57A					330h: 59A					450h: 71A					640h: 77A					330h: 59A					450h: 71A					640h: 77A					890h: 85A				
		210hs: 69A					330hs: 87A					450hs: 106A					640hs: 108A					330hs: 87A					450hs: 106A					640hs: 108A					890hs: 118A				
Heating Power	kW	8.1	8.4	9.0	9.6	12.5	9.0	9.6	12.5	14.3	12.5	14.3	16.5	14.3	16.5	18.7	9.0	9.6	12.5	14.3	12.5	14.3	16.5	14.3	16.5	18.7	16.5	18.7	24.0												
Temperature Control Zone	Zone	3+1			4+1			3+1			4+1			4+1			4+1			3+1			4+1			4+1			4+1												
Max. System Pressure	MPa	17.5					17.5					17.5					17.5					17.5					17.5					17.5									
Oil Tank Capacity	L	90					90					90					90					150					150					150									
Machine Dimensions (LxWxH)	m	5.67x1.52x2.05					5.74x1.52x2.05					5.94x1.52x2.05					6.16x1.52x2.05					6.33x1.63x2.19					6.33x1.63x2.19					6.44x1.63x2.19					6.75x1.63x2.19				
Machine Weight	T	5.8					6.5					6.8					7.0					7.4					7.7					8.0					8.3				

\*To enhance the using experience, the company keeps upgrading the products and reserves the right to change the product specification and parameters without prior notice. The final interpretation to the above specification and parameters belongs to the company.

# SPARK EH | Specifications

Specifications	Unit	EH230												EH300																			
Injection Unit		A	B	C	A	B	C	A	B	C	A	B	C	A	B	C	A	B	C	A	B	C	A	B	C								
Screw Diameter	mm	36	40	45	40	45	50	45	50	55	50	55	60	45	50	55	50	55	60	55	60	65	60	65	70								
Screw L/D Ratio	/	21	21	21	21	21	21	21	21	21	21	21	21	21	21	21	21	21	21	21	21	21	22	21	22	22							
Theoretical Shot Volume	cm <sup>3</sup>	183	226	286	251	318	393	358	442	535	491	594	707	358	442	535	491	594	707	653	778	913	848	995	1155								
Shot Weight (PS)	g	166	205	260	228	289	357	325	402	486	446	540	643	325	402	486	446	540	643	594	707	830	771	905	1051								
Injection Pressure	MPa	247	200	158	253	200	162	247	200	165	218	180	151	247	200	165	218	180	151	214	180	153	211	180	155								
Holding Pressure	MPa	198	160	126	202	160	130	198	160	132	174	144	121	198	160	132	174	144	121	171	144	122	169	144	124								
Injection Unit Model		450			640			890			1100			890			1100			1400			1800										
Injection Rate	cm <sup>3</sup> /s	203	251	318	201	254	314	255	314	380	314	380	452	255	314	380	314	380	452	380	453	531	452	531	616								
Injection Speed	mm/s	200	200	200	160	160	160	160	160	160	160	160	160	160	160	160	160	160	160	160	160	160	160	160	160								
Injection Unit Model		450h			640h			890h			1100h			890h			1100h			1400h			1800h										
Injection Rate	cm <sup>3</sup> /s	305	377	477	314	398	491	398	491	594	491	594	707	398	491	594	491	594	707	594	707	830	707	828	963								
Injection Speed	mm/s	300	300	300	250	250	250	250	250	250	250	250	250	250	250	250	250	250	250	250	250	250	250	250	250								
Injection Unit Model		450hs			640hs			890hs			1100hs			890hs			1100hs			1400hs			1800hs										
Injection Rate	cm <sup>3</sup> /s	508	628	794	439	557	688	557	688	832	687	832	990	557	688	832	687	832	990	831	990	1162	989	1161	1348								
Injection Speed	mm/s	500	500	500	350	350	350	350	350	350	350	350	350	350	350	350	350	350	350	350	350	350	350	350	350								
Injection Stroke (Max.)	mm	180	180	180	200	200	200	225	225	225	250	250	250	225	225	225	250	250	250	275	275	275	300	300	300								
Screw Speed (Max.)	rpm	400	400	400	350	350	350	320	320	320	320	320	320	320	320	320	320	320	320	300	300	300	250	250	250								
Nozzle Contact Force (Max.)	kN	62	62	62	62	62	62	91	91	91	91	91	91	91	91	91	91	91	91	91	91	91	91	91	91								
Nozzle Stroke (Max.)	mm	400	400	400	400	400	400	400	400	400	400	400	400	400	430	430	430	430	430	430	430	430	430	430	430								
<b>Camping Unit</b>																																	
Clamping Force	kN	2300												3000																			
Mold Opening Stroke	mm	550												600																			
Mold Dimensions	mm	890x885.5												1080x1070																			
Space Between Tie Bars (HxV)	mm	610x610												730x730																			
Mold Force (Min.-Max.)	mm	250-680												300-750																			
Max. Daylight	mm	1230												1350																			
Ejector Force	kN	67												67																			
Ejector Stroke	mm	150												160																			
No. of Ejector Pins	PCS	12+1												12+1																			
Locating Ring Diameter	mm	125												160																			
<b>Others</b>																																	
Total Power Capacity	kW	450: 43kW				640: 46kW				890: 51kW				1100: 63kW				890: 57kW				1100: 69kW				1400: 80kW				1800: 83kW			
		450h: 43kW				640h: 46kW				890h: 51kW				1100h: 63kW				890h: 57kW				1100h: 69kW				1400h: 80kW				1800h: 83kW			
		450hs: 60kW				640hs: 61kW				890hs: 67kW				1100hs: 76kW				890hs: 67kW				1100hs: 76kW				1400hs: 92kW				1800hs: 103kW			
Max. Rated Current	A	450: 76A				640: 82A				890: 90A				1100: 111A				890: 100A				1100: 121A				1400: 141A				1800: 147A			
		450h: 76A				640h: 82A				890h: 90 A				1100h: 111A				890h: 100A				1100h: 121A				1400h: 141A				1800h: 147A			
		450hs: 106A				640hs: 108A				890hs: 118A				1100hs: 135A				890hs: 118A				1100hs: 135A				1400hs: 163A				1800hs: 181A			
Heating Power	kW	12.5	14.3	16.5	14.3	16.5	18.7	16.5	18.7	24.0	18.7	24.0	26.8	16.5	18.7	24.0	18.7	24.0	26.8	24.0	26.8	36.1	26.8	36.1	38.8								
Temperature Control Zone	Zone	4+1				4+1				4+1				4+1				4+1				4+1				4+1				5+1			
Max. System Pressure	MPa	17.5				17.5				17.5				17.5				17.5				17.5				17.5				17.5			
Oil Tank Capacity	L	150				150				150				150				160				160				160				160			
Machine Dimensions (LxWxH)	m	6.82x1.72x2.30				6.83x1.72x2.30				7.14x1.72x2.30				7.37x1.72x2.30				7.75x1.98x2.47				7.78x1.98x2.47				8.13x1.98x2.47				8.31x1.98x2.47			
Machine Weight	T	10.2				10.5				10.8				11.2				14.5				14.9				15.2				15.5			

\*To enhance the using experience, the company keeps upgrading the products and reserves the right to change the product specification and parameters without prior notice. The final interpretation to the above specification and parameters belongs to the company.

# SPARK EH | Specifications

Specifications	Unit	EH360												EH450																			
Injection Unit		A	B	C	A	B	C	A	B	C	A	B	C	A	B	C	A	B	C	A	B	C	A	B	C								
Screw Diameter	mm	50	55	60	55	60	65	60	65	70	67	75	83	55	60	65	60	65	70	67	75	83	75	83	90								
Screw L/D Ratio	/	21	21	21	21	21	22	21	22	22	23.5	21	19	21	21	22	21	22	22	23.5	21	19	23.2	21	19.4								
Theoretical Shot Volume	cm <sup>3</sup>	491	594	707	653	778	913	848	995	1155	1181	1480	1813	653	778	913	848	995	1155	1181	1480	1813	1657	2029	2386								
Shot Weight (PS)	g	446	540	643	594	707	830	771	905	1051	1074	1346	1649	594	707	830	771	905	1051	1074	1346	1649	1507	1846	2171								
Injection Pressure	MPa	218	180	151	214	180	153	211	180	155	226	180	147	214	180	153	211	180	155	226	180	147	220	180	153								
Holding Pressure	MPa	174	144	121	171	144	122	169	144	124	181	144	118	171	144	122	169	144	124	181	144	118	176	144	122								
Injection Unit Model		1100			1400			1800			2700			1400			1800			2700			3600										
Injection Rate	cm <sup>3</sup> /s	314	380	452	380	453	531	452	531	616	564	707	866	380	453	531	452	531	616	564	707	866	707	866	1018								
Injection Speed	mm/s	160	160	160	160	160	160	160	160	160	160	160	160	160	160	160	160	160	160	160	160	160	160	160	160								
Injection Unit Model		1100h			1400h			1800h			2700h			1400h			1800h			2700h			3600h										
Injection Rate	cm <sup>3</sup> /s	491	594	707	594	707	830	707	829	963	881	1104	1353	594	707	830	707	829	963	881	1104	1353	1105	1353	1591								
Injection Speed	mm/s	250	250	250	250	250	250	250	250	250	250	250	250	250	250	250	250	250	250	250	250	250	250	250	250								
Injection Unit Model		1100hs			1400hs			1800hs			-			1400hs			1800hs			-			-										
Injection Rate	cm <sup>3</sup> /s	687	832	990	831	990	1162	989	1161	1348	-	-	-	831	990	1162	989	1161	1348	-	-	-	-	-	-								
Injection Speed	mm/s	350	350	350	350	350	350	350	350	350	-	-	-	350	350	350	350	350	350	-	-	-	-	-	-								
Injection Stroke (Max.)	mm	250	250	250	275	275	275	300	300	300	335	335	335	275	275	275	300	300	300	335	335	335	375	375	375								
Screw Speed (Max.)	rpm	320	320	320	300	300	300	250	250	250	250	250	250	300	300	300	250	250	250	250	250	250	230	230	230								
Nozzle Contact Force (Max.)	kN	91	91	91	91	91	91	91	91	91	91	91	91	91	91	91	91	91	91	91	91	91	91	91	91								
Nozzle Stroke (Max.)	mm	430	430	430	430	430	430	430	430	430	430	430	430	470	470	470	470	470	470	470	470	470	470	470	470								
<b>Camping Unit</b>																																	
Clamping Force	kN	3600												4500																			
Mold Opening Stroke	mm	700												820																			
Mold Dimensions	mm	1160x1165												1290x1290																			
Space Between Tie Bars (HxV)	mm	830x830												920x920																			
Mold Force (Min.-Max.)	mm	300-850												330-810																			
Max. Daylight	mm	1550												1630																			
Ejector Force	kN	67												98																			
Ejector Stroke	mm	180												180																			
No. of Ejector Pins	PCS	12+1												12+1																			
Locating Ring Diameter	mm	160												200																			
<b>Others</b>																																	
Total Power Capacity	kW	1100: 77kW				1400: 88kW				1800: 91kW				2700: 115kW				1400: 98kW				1800: 101kW				2700: 124kW				3600: 160kW			
		1100h: 77kW				1400h: 88kW				1800h: 91kW				2700h: 115kW				1400h: 98kW				1800h: 101kW				2700h: 124kW				3600h: 160kW			
		1100hs: 77kW				1400hs: 92kW				1800hs: 103kW				-				1400hs: 98kW				1800hs: 103kW				-							
Max. Rated Current	A	1100: 136A				1400: 156A				1800: 162A				2700: 203A				1400: 172A				1800: 178A				2700: 219A				3600: 282A			
		1100h: 136A				1400h: 156A				1800h: 162A				2700h: 203A				1400h: 172A				1800h: 178A				2700h: 219A				3600h: 282A			
		1100hs: 136A				1400hs: 163A				1800hs: 181A				-				1400hs: 172A				1800hs: 181A				-							
Heating Power	kW	18.7	24.0	26.8	24.0	26.8	36.1	26.8	36.1	38.8	34.4	34.4	34.4	24.0	26.8	36.1	26.8	36.1	38.8	34.4	34.4	34.4	39.6	39.6	39.6								
Temperature Control Zone	Zone	4+1			4+1			5+1			4+1			5+1			4+1			5+1			4+1			5+1							
Max. System Pressure	MPa	17.5				17.5				17.5				17.5				17.5				17.5				17.5							
Oil Tank Capacity	L	180				180				180				180				180				180				180							
Machine Dimensions (LxWxH)	m	8.65x2.14x2.50				8.65x2.14x2.50				8.82x2.14x2.50				9.15x2.14x2.50				8.65x2.13x2.55				8.65x2.13x2.55				8.97x2.13x2.55				9.33x2.13x2.55			
Machine Weight	T	17.8				18.1				18.5				18.7				23.0				23.2				23.4				23.8			

\*To enhance the using experience, the company keeps upgrading the products and reserves the right to change the product specification and parameters without prior notice. The final interpretation to the above specification and parameters belongs to the company.

# SPARK EH | Specifications

Specifications	Unit	EH550												EH650									
		A	B	C	A	B	C	A	B	C	A	B	C	A	B	C	A	B	C	A	B	C	
<b>Injection Unit</b>																							
Screw Diameter	mm	60	65	70	67	75	83	75	83	90	83	90	98	67	75	83	75	83	90	83	90	98	
Screw L/D Ratio	/	21	22	22	23.5	21	19	23.2	21	19.4	23.9	22	20.2	23.5	21	19	23.2	21	19.4	23.9	22	20.2	
Theoretical Shot Volume	cm <sup>3</sup>	848	995	1155	1181	1480	1813	1657	2029	2386	2435	2863	3394	1181	1480	1813	1657	2029	2386	2435	2863	3394	
Shot Weight (PS)	g	771	905	1051	1074	1346	1649	1507	1846	2171	2215	2605	3088	1074	1346	1649	1507	1846	2171	2215	2605	3088	
Injection Pressure	MPa	211	180	155	226	180	147	220	180	153	213	181	153	226	180	147	220	180	153	213	181	153	
Holding Pressure	MPa	169	144	124	181	144	118	176	144	122	170	145	122	181	144	118	176	144	122	170	145	122	
Injection Unit Model		1800			2700			3600			5200			2700			3600			5200			
Injection Rate	cm <sup>3</sup> /s	452	531	616	564	707	866	707	866	1018	866	1018	1207	564	707	866	707	866	1018	866	1018	1207	
Injection Speed	mm/s	160	160	160	160	160	160	160	160	160	160	160	160	160	160	160	160	160	160	160	160	160	
Injection Unit Model		1800h			2700h			3600h			-			2700h			3600h			-			
Injection Rate	cm <sup>3</sup> /s	707	829	963	881	1104	1353	1105	1353	1591	-	-	-	881	1104	1353	1105	1353	1591	-	-	-	
Injection Speed	mm/s	250	250	250	250	250	250	250	250	250	-	-	-	250	250	250	250	250	250	-	-	-	
Injection Unit Model		1800hs			-			-			-			-			-			-			
Injection Rate	cm <sup>3</sup> /s	989	1161	1348	-	-	-	-	-	-	-	-	-	-	-	-	-	-	-	-	-	-	
Injection Speed	mm/s	350	350	350	-	-	-	-	-	-	-	-	-	-	-	-	-	-	-	-	-	-	
Injection Stroke (Max.)	mm	300	300	300	335	335	335	375	375	375	450	450	450	335	335	335	375	375	375	450	450	450	
Screw Speed (Max.)	rpm	250	250	250	250	250	250	230	230	230	230	230	230	250	250	250	230	230	230	230	230	230	
Nozzle Contact Force (Max.)	kN	91	91	91	91	91	91	91	91	91	91	91	91	91	91	91	91	91	91	91	91	91	
Nozzle Stroke (Max.)	mm	520	520	520	520	520	520	520	520	520	520	520	520	560	560	560	560	560	560	560	560	560	
<b>Camping Unit</b>																							
Clamping Force	kN	5500												6500									
Mold Opening Stroke	mm	900												1000									
Mold Dimensions	mm	1400x1400												1560x1560									
Space Between Tie Bars (HxV)	mm	980x980												1090x1090									
Mold Force (Min.-Max.)	mm	400~900												420~1000									
Max. Daylight	mm	1800												2000									
Ejector Force	kN	154												220									
Ejector Stroke	mm	200												200									
No. of Ejector Pins	PCS	12+1												12+1									
Locating Ring Diameter	mm	200												200									
<b>Others</b>																							
Total Power Capacity	kW	1800: 118kW			2700: 141kW			3600: 149kW			5200: 152kW			2700: 149kW			3600: 156kW			5200: 159W			
		1800h: 118kW			2700h: 141kW			3600h: 149kW			-			2700h: 149kW			3600h: 156kW			-			
		1800hs: 118kW			-			-			-			-			-			-			
Max. Rated Current	A	1800: 208A			2700: 248A			3600: 262A			5200: 268A			2700: 261A			3600: 275A			5200: 281A			
		1800h: 208A			2700h: 248A			3600h: 262A			-			2700h: 261A			3600h: 275A			-			
		1800hs: 208A			-			-			-			-			-			-			
Heating Power	kW	26.8	36.1	38.8	34.4	34.4	34.4	39.6	39.6	39.6	48.5	48.5	48.5	34.4	34.4	34.4	39.6	39.6	39.6	48.5	48.5	48.5	
Temperature Control Zone	Zone	4+1		5+1		5+1		5+1		6+1		5+1		5+1		5+1		6+1		6+1		6+1	
Max. System Pressure	MPa	17.5			17.5			17.5			17.5			17.5			17.5			17.5			
Oil Tank Capacity	L	250			250			250			250			300			300			300			
Machine Dimensions (LxWxH)	m	9.4x2.3x2.6			9.4x2.3x2.6			9.4x2.3x2.6			9.5x2.3x2.6			10.2x2.5x2.65			10.3x2.5x2.65			10.3x2.5x2.65			
Machine Weight	T	26.9			27.6			29.0			30.0			34.8			35.3			36.3			

\*To enhance the using experience, the company keeps upgrading the products and reserves the right to change the product specification and parameters without prior notice. The final interpretation to the above specification and parameters belongs to the company.

# SPARK EH | Features

P.S. ●Standard, ○Optional, ×Not Available, Numbers indicate required quantities.

	CONFIGURATIONS	SPARK EH
INJECTION UNIT	1. Ceramic Heater Band	●
	2. Infrared Heater Band	○
	3. Barrel Insulation Cover	○
	4. Insulated Barrel Guard	●
	5. Wear-Resistant Screw and Barrel Unit	●
	6. Bimetallic Screw and Barrel	○
	7. Bimetallic Screw and Barrel Set	○
	8. Special Screw and Barrel Set For PEF/PVC	○
	9. Custom Screw and Nozzle	○
	10. Shot-Off Nozzle	○
	11. Carriage Linear Transducer	○
	12. Screw RPM Display	●
	13. Barrel Cooling Control	●
	14. Simultaneous Plasticising	●
	15. Automatic PID Temperature Control	●
	16. Proportional Back Pressure	●
	17. Thermocouple Open Circuit Detection	●
	18. Nozzle Blockage and Overflow Detection	●
	19. Locking Type Screw Tip Set	○
	20. Hydraulic/Pneumatic Sequential Injection	○
	21. Dual Injection	●
	22. Low Pressure Injection	●
	23. Linear Rail	●
	24. Injection Compression Molding	●
	25. Barrel Inlet Cooling Water Automatic Control	●
	26. Spray Painting Hopper	○
	27. Color Masterbatch Feeder Interface	○
	28. Smaller/Larger Injection Unit	○

	CONFIGURATIONS	SPARK EH
CLAMPING UNIT	1. Auto-Clamping Force Adjustment	○
	2. Eurmap 2	○
	3. Fully Automatic Intelligent Distribution Centralised Lubrication System	●
	4. Core Pull One Set	○
	5. Multiple Core Pull (Hydraulic/ Pneumatic)	○
	6. One Set of Air Blowing for the First and Second Platens Each	●
	7. Multiple Air Blow	○
	8. Product Chute	○
	9. High-Spend Clamping Force	●
	10. High-Precision Chrome-Plated Tie Bar	●
	11. Auto-Front Door	○
	12. Auto-Clamping Force Control	●
	13. Safety Door Electromagnetic Locking Device	●
	14. Ejector On the Fly	●
	15. In-Mold Ejector	●
	16. Dual Ejector	●
	17. Centre Ejector Rod Reverse Pull Mechanism	●
	18. Clamping Unit Linear Guide	●
	19. Custom Mold	○
	20. Hot Runner Pin	○

	CONFIGURATIONS	SPARK EH
CONTROL UNIT	1. CHE Controller	●
	2. 15"HD TF Touch-Screen Display	●
	3. International Units (Metric/Imperial Freely Switchable)	●
	4. High Dynamic Response Safety Servo Assembly Compliant With STO Standards	●
	5. High-Precision Mold Safety	●
	6. High-Speed Control base on EtherCAT	●
	7. Euromap 12 Robot Interface	○
	8. Euromap 67 Robot Interface	○
	9. Euromap 18 Robot Interface	○
	10. Euromap 13 Coll Pull/Ejector Signal Interface	○
	11. Euromap 70 and 70.1	○
	12. USB Interface	●
	13. OPC--UA	●
	14. Free I/O Board	●
	15. LED Back Light	●
	16. Three Color LED Alarm Light	●
	17. Variable Servo Rigidity System	●
	18. Solid State Relay	●
	19. Robot Interface (Non-European)	●
	20. Magnetic (Hydraulic) Mold Clamp System Interface	○
	21. Sequential/Hydraulic/Electric Unscrewing	○
	22. Gas-Assisted Control Electrical Interface	○
	23. Heater Break Detection	○
	24. Energy-Saving Heating System	○
	25. Micro-Foaming Control System Interface	○
	26. Hot Runner Control System	○

	CONFIGURATIONS	SPARK EH
OTHERS	1. Three-Phase 380V 32A Power Supplies - Two Sets Single-Phase 220V 32A Power Supply - One Set Single-Phase 220V 10A Power Supply - One Set	20 - 360T
	2. Three-Phase 380V 32A Power Supplies - Two Sets Three-Phase 380V 32A Power Supplies - One Set Single-Phase 220V 10A Power Supply - One Set	450 - 650T
	3. D10 Quick Connector Mold Cooling Water - 5 Sets	20 - 180T
	4. D10 Quick Connector Mold Cooling Water - 7 Sets	230 - 650T



\*To enhance the using experience, the company keeps upgrading the products and reserves the right to change the product specification and parameters without prior notice. The final interpretation to the above specification and parameters belongs to the company.

# SPARK EH | Mold and Machine Dimensions

## EH100

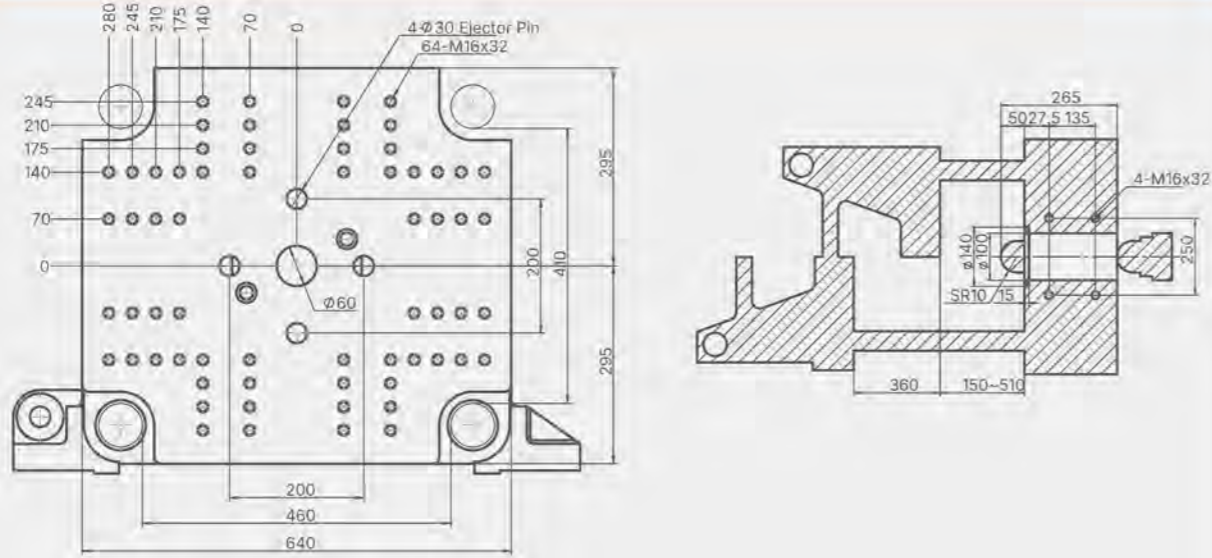

Machine Dimensions (LxWxH)

Injection Unit Model	A	B	C	D	E
160	4662	708	1605	1828	184
210	4812	858	1605	1828	172

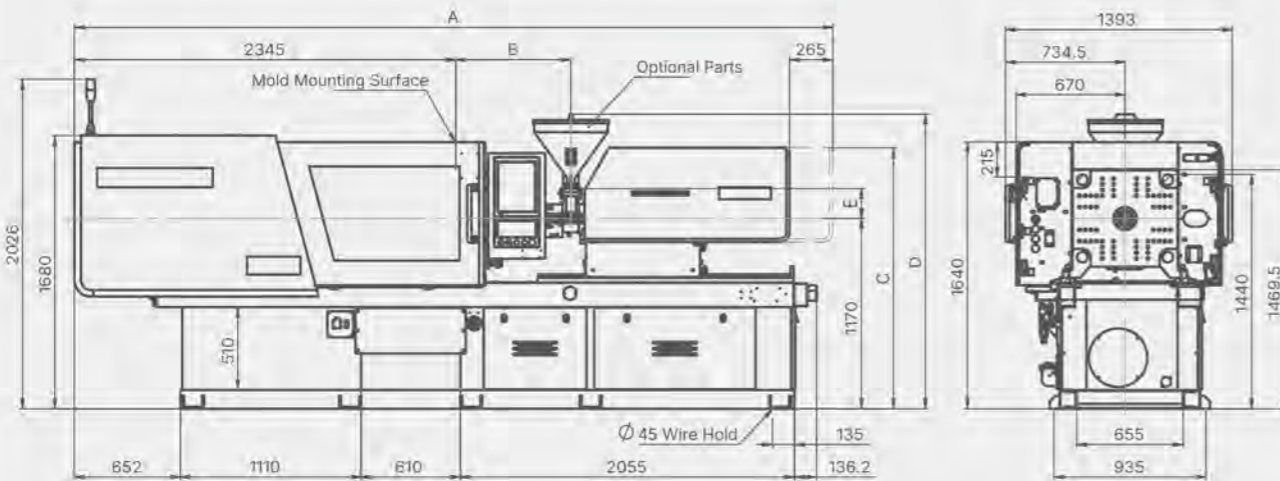

## EH120

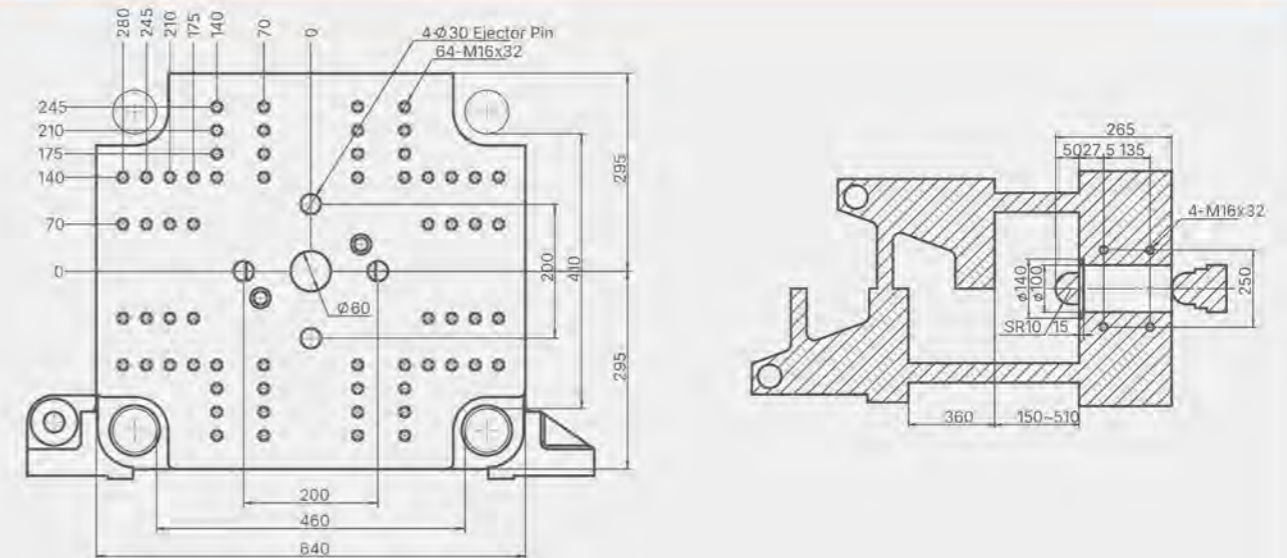

Machine Dimensions (LxWxH)

Injection Unit Model	A	B	C	D	E
160	4662	708	1605	1828	184
210	4812	858	1605	1820	172
330	5140	887	1660	1848	210
450	5344	1091	1660	1853	215

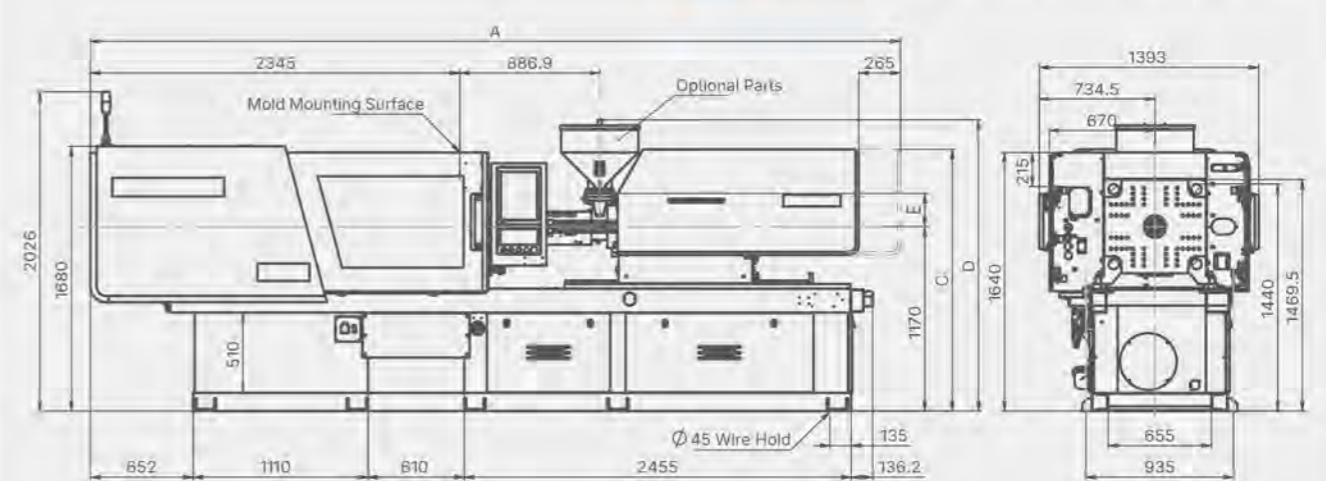

\*To enhance the using experience, the company keeps upgrading the products and reserves the right to change the product specification and parameters without prior notice. The final interpretation to the above specification and parameters belongs to the company.

# SPARK EH | Mold and Machine Dimensions

## EH150

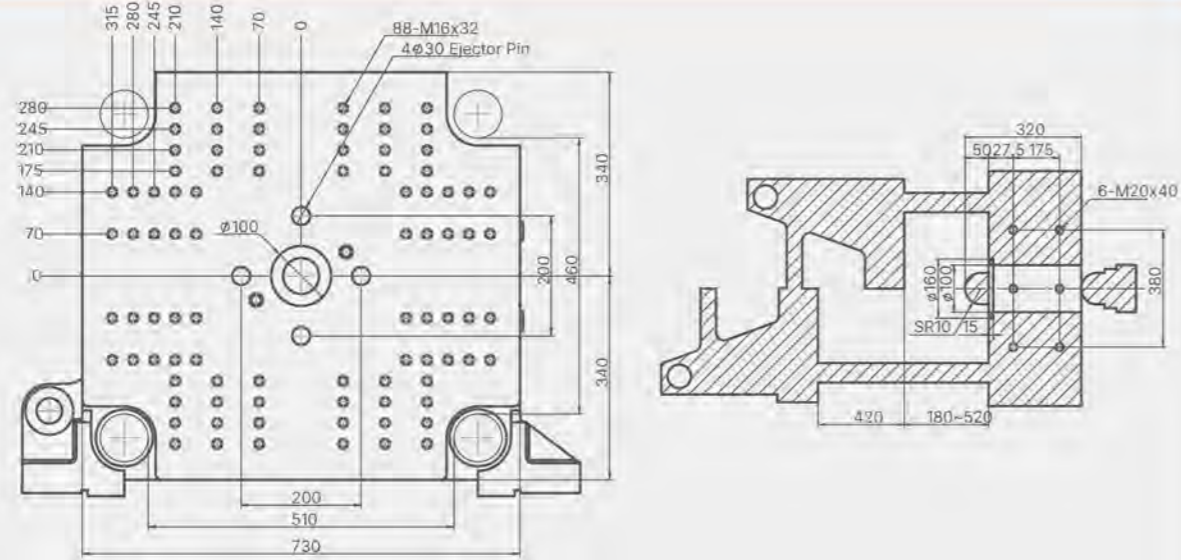

Machine Dimensions (LxWxH)

Injection Unit Model	A	B	C	D	E
210	5408	798	1580.5	1729	172
330	5737	888	1635.5	1772	215
450	5940	982	1635.5	1772	215
640	6158	1091	1640.5	1772	215

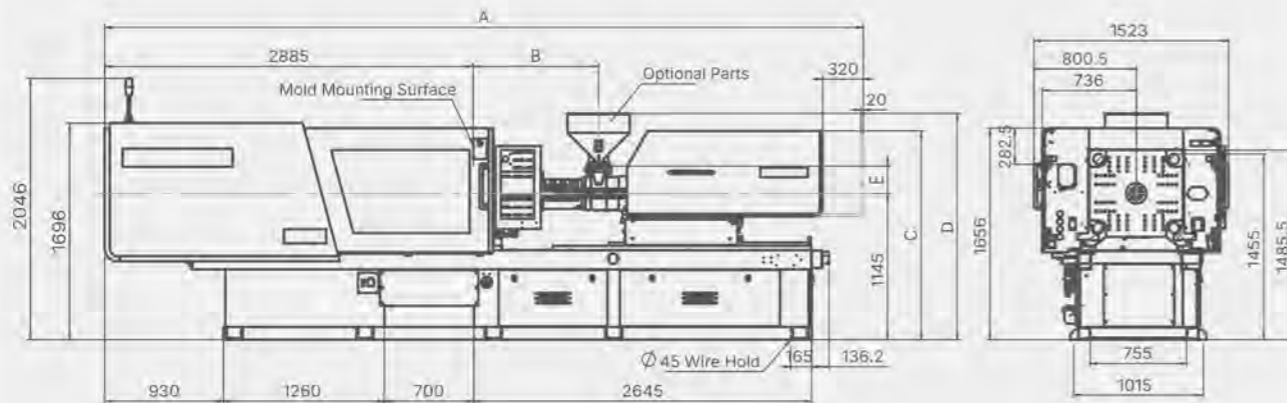

\*To enhance the using experience, the company keeps upgrading the products and reserves the right to change the product specification and parameters without prior notice. The final interpretation to the above specification and parameters belongs to the company.

## EH180

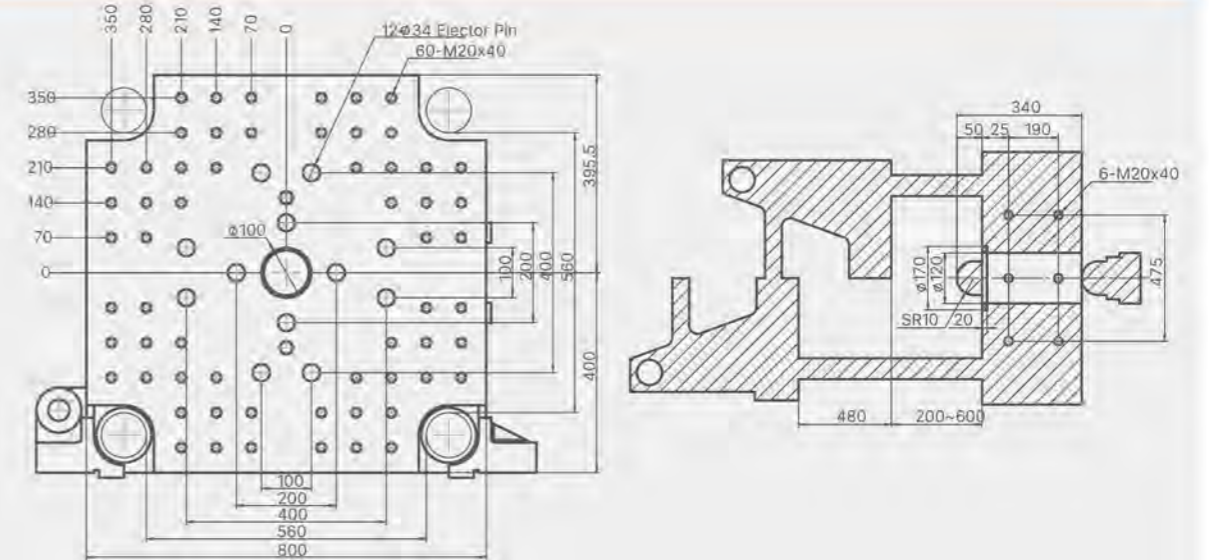

Machine Dimensions (LxWxH)

Injection Unit Model	A	B	C	D	E
330	6015	887	1715.5	1847	210
450	6219	982	1715.5	1852	215
640	6437	1092	1720.5	1852	215
890	6750	1202	1835.5	2031	217

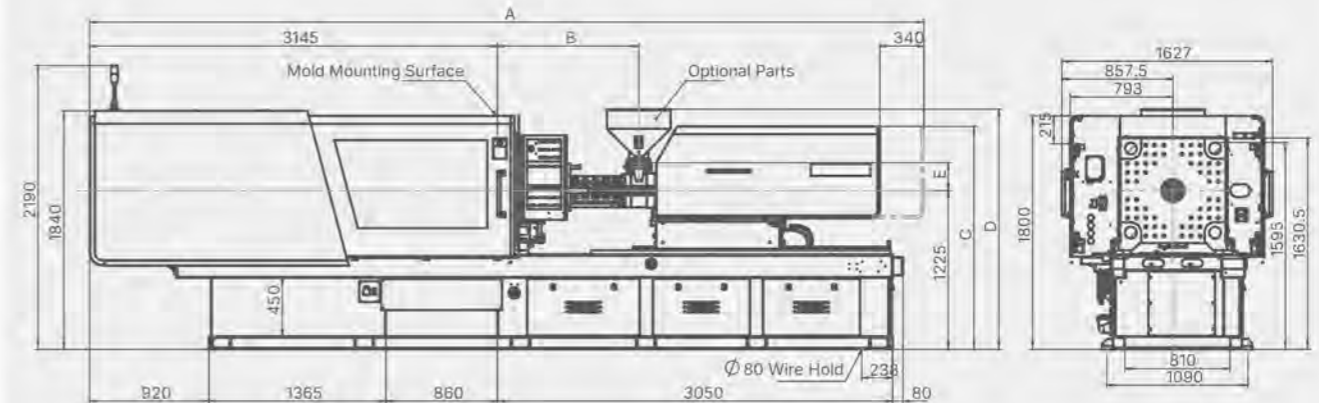

# SPARK EH | Mold and Machine Dimensions

## EH230

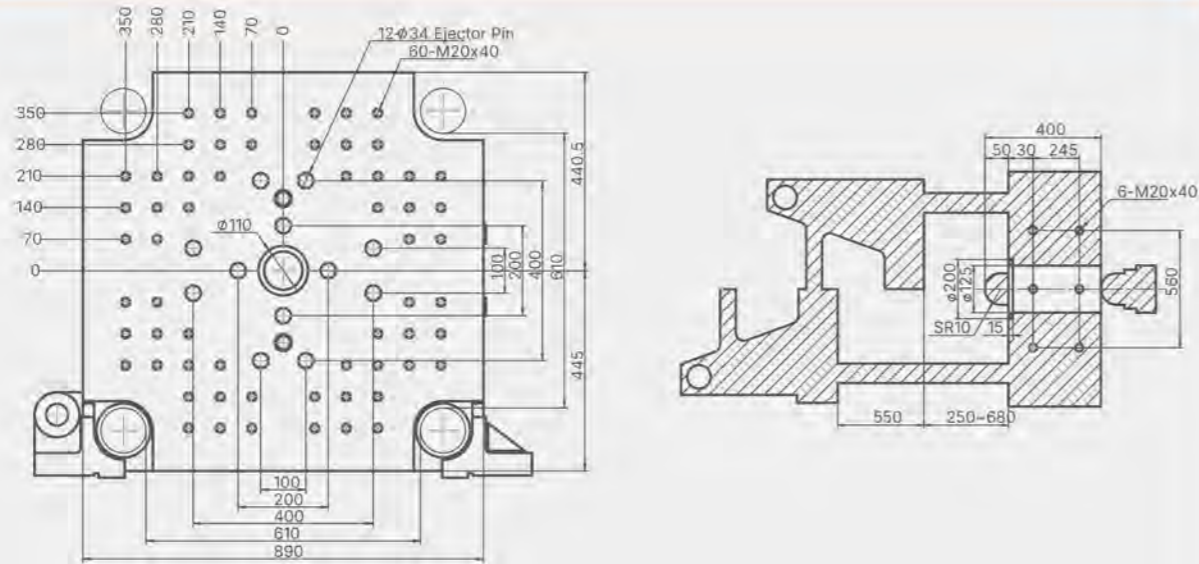

Machine Dimensions (LxWxH)

Injection Unit Model	A	B	C	D	E
450	6607.5	982	1790.5	1927.5	215
640	6825	1092	1795.5	1927.5	215
890	7138.5	1202	1910.5	2106.5	217
1100	7368.5	1332	1910.5	2106.5	217

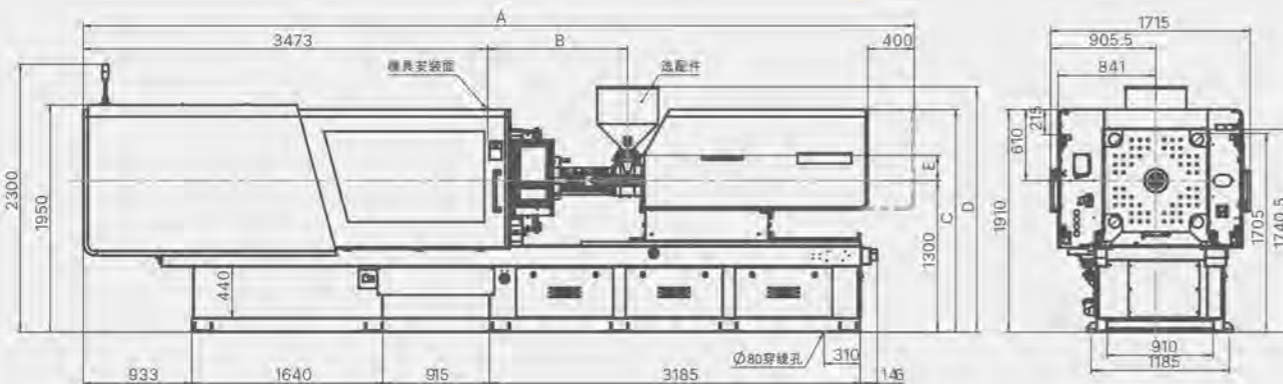

\*To enhance the using experience, the company keeps upgrading the products and reserves the right to change the product specification and parameters without prior notice. The final interpretation to the above specification and parameters belongs to the company.

## EH300

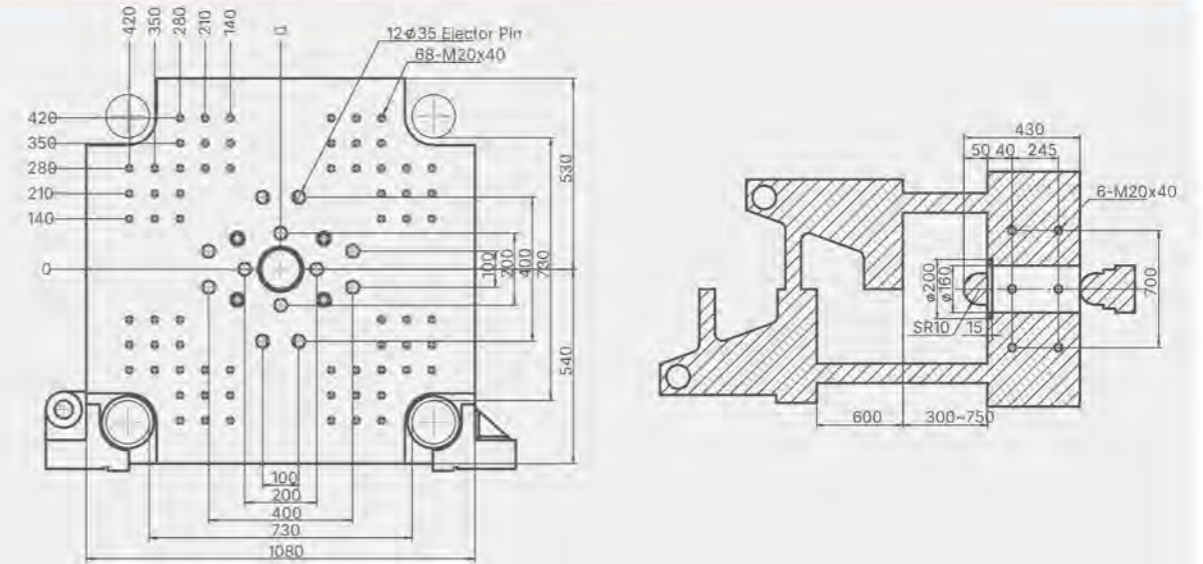

Machine Dimensions (LxWxH)

Injection Unit Model	A	B	C	D	E
890	7645	1202	2001	2197	217
1100	7775	1332	2001	2197	217
1400	8130	1452	2050	2197	217
1800	8309	1631	2050	2197	217

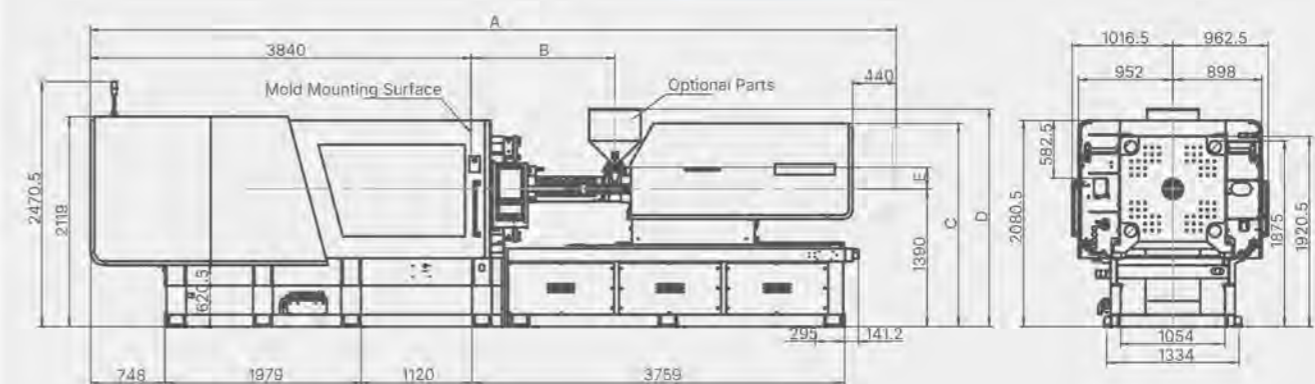





# SPARK EH | Optional: T-Slot + Mount Hole Mold Platen

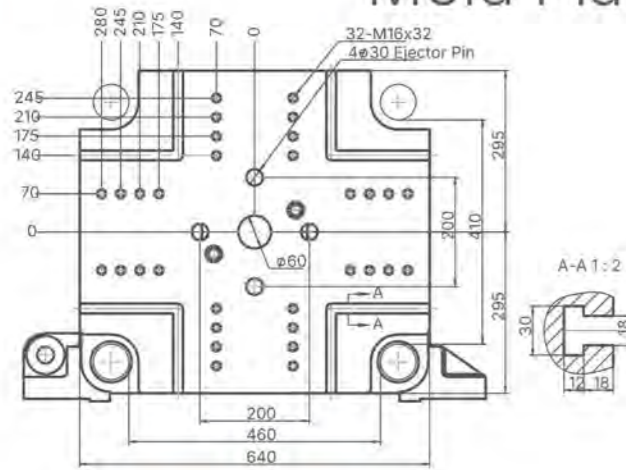

EH100-EH120

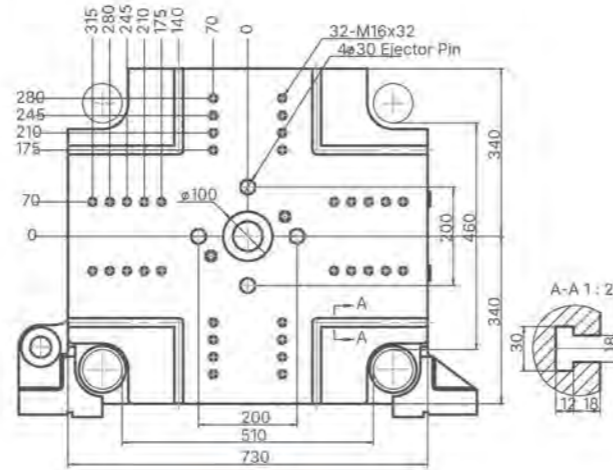

EH150

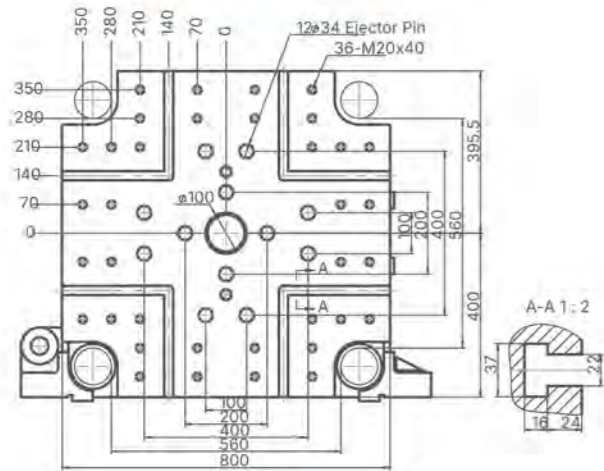

EH180

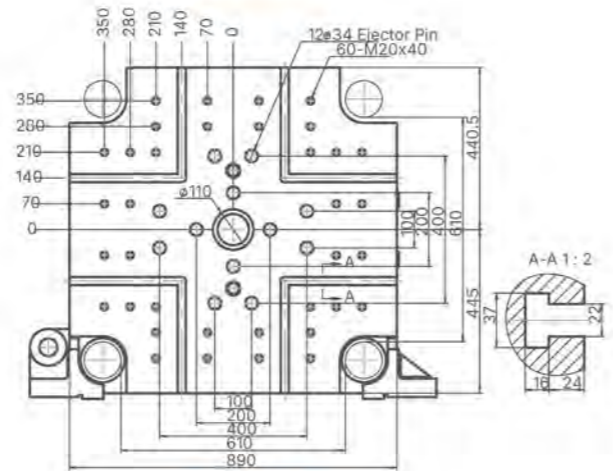

EH230

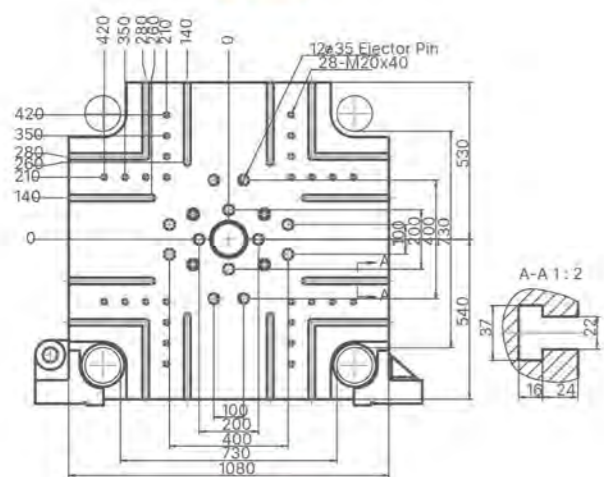

EH300

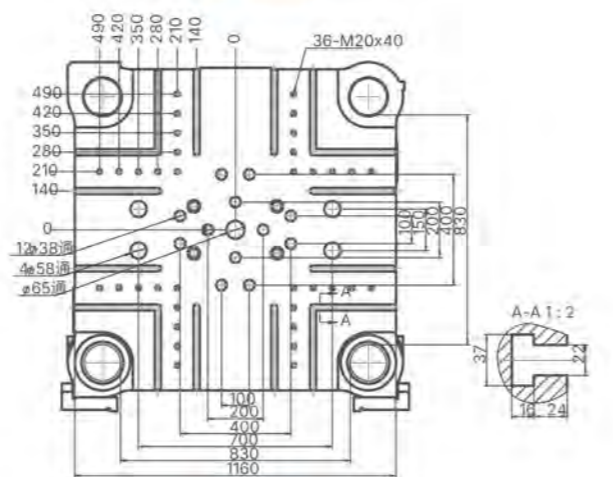

EH360

# SPARK Series | Robot Arm Dimensions Drawing

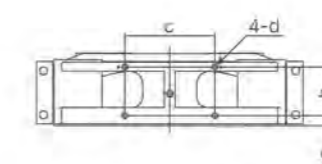
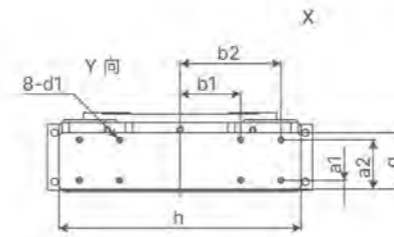
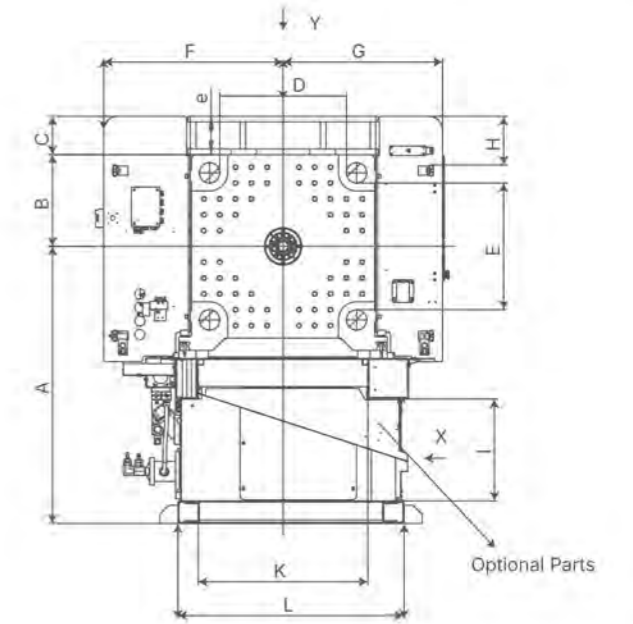
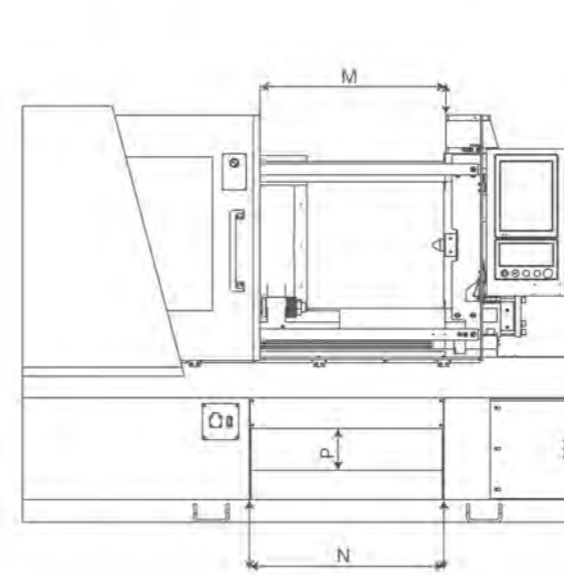

100/120 Fixed Platen

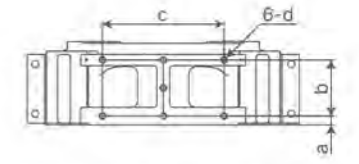

150/180/230/300/360/450 Fixed Platen

## SPARK AE

Model	A	B	C	D	E	F	G	H	I	K	L	M	N	P	a	b	c	d	d1	e	g	h	a1	a2	b1	b2
AE100	1170	300	170	460	410	670	594	215	510	630	865	710	610	170	27.5	135	250	M16x32	M16x32	170	136	620	34	104	175	280
AE120	1170	300	170	460	410	670	594	215	510	630	865	710	610	170	27.5	135	250	M16x32	M16x32	170	136	620	34	104	175	280
AE150	1145	300	170	510	460	730	658	215	450	710	945	800	690	140	27.5	175	380	M20x40	M16x32	170	136	620	34	104	175	280
AE180	1225	405	170	560	560	793	705	215	450	750	1000	810	860	145	25	190	475	M20x40	M20x40	170	196	840	35	175	210	350
AE230	1300	440	170	610	610	841	745	215	440	845	1095	970	915	140	30	245	560	M20x40	M20x40	170	196	840	35	175	210	350
AE300	1390	530	160	730	730	952	818	223	295	1006	1254	1300	1120	295	40	245	700	M20x40	M20x40	160	206	1050	35	175	350	490
AE360	1395	608	97	830	830	1030	976	163	215	970	1218	1335	1200	215	90	140	780	M20x40	M20x40	160	206	1190	35	175	350	490
AE450	1500	675	0	920	920	1068	938	87	290	1273	1433	1553	1200	/	85	140	910	M20x40	M20x40	160	206	1320	35	175	420	560

## SPARK EH

Model	A	B	C	D	E	F	G	H	I	K	L	M	N	P	a	b	c	d	d1	e	g	h	a1	a2	b1	b2
EH100	1170	300	170	460	410	670	594	215	510	630	865	710	610	170	27.5	135	250	M16x32	M16x32	170	136	620	34	104	175	280
EH120	1170	300	170	460	410	670	594	215	510	630	865	710	610	170	27.5	135	250	M16x32	M16x32	170	136	620	34	104	175	280
EH150	1145	300	170	510	460	730	658	215	450	710	945	800	690	140	27.5	175	380	M20x40	M16x32	170	136	620	34	104	175	280
EH180	1225	405	170	560	560	793	705	215	450	750	1000	810	860	145	25	190	475	M20x40	M20x40	170	196	840	35	175	210	350
EH230	1300	440	170	610	610	841	745	215	440	845	1095	970	915	140	30	245	560	M20x40	M20x40	170	196	840	35	175	210	350
EH300	1390	530	160	730	730	952	818	223	295	1006	1254	1300	1120	295	40	245	700	M20x40	M20x40	160	206	1050	35	175	350	490
EH360	1395	608	97	830	830	1030	976	163	215	970	1218	1335	1200	215	90	140	780	M20x40	M20x40	160	206	1190	35	175	350	490
EH450	1500	675	0	920	920	1068	938	87	290	1273	1433	1553	1200	/	85	140	910	M20x40	M20x40	160	206	1320	35	175	420	560

\*To enhance the using experience, the company keeps upgrading the products and reserves the right to change the product specification and parameters without prior notice. The final interpretation to the above specification and parameters belongs to the company.



Engineered for Multi-Material Excellence



"Your Vision is Our Mission"

Encounter Chen Hsong's craftsmanship where least expected





“Your Vision is Our Mission”