



YouTube



Facebook



LinkedIn

CHEN HSONG

Add.: Unit 2001, 20th Floor, Citicorp
Centre, 18 Whitfield Road,
Hong Kong

Tel.: +852 2665-3888 | 2665-3222

Email: mr@chenhsong.com

Web.: www.chenhsong.com

CH 20260409-CV

SUPER PACK

High-Speed Packaging Series | For Thin-Wall Packaging

270-430T



CHEN HSONG

Powering Your Future in Intelligent Injection Molding

Driven by its founding principle, "Your Vision is Our Mission", the Chen Hsong Group, established in 1958 and publicly listed in Hong Kong since 1991, has evolved over nearly 70 years from an injection molding machine manufacturer into a one-stop total solutions provider in plastics manufacturing. As one of the world's largest producers of injection molding machines, Chen Hsong achieves unmatched quality through complete in-house manufacturing. This vertically integrated approach means controlling everything from ductile iron castings, parts fabrication and core components (such as advanced controllers) to final assembly. With a comprehensive product matrix serving diverse industries like automotive and medical, we are also spearheading smart manufacturing upgrades through the iChen™ Smart Family Suite, including the iChen™ Smart Factory MES, iChen™ Cloud platform, and iChen™ AI Molder, making the path to Industry 4.0 easily accessible for our global clientele.

1,000,000m²

R&D and Production Facilities (Five locations)

85+

Countries Globally

1,000,000+

Injection Molding Machines in the Field



Hong Kong Headquarters



Shenzhen Industrial Park Facility **560000m²**



Taiwan Taoyuan Facility **30000m²**



Foshan Shunde - Two Facilities **150000m²**



Zhejiang Ningbo Facility **70000m²**



Shanwei Luhe Facility **62360m²**

Over 1 Million+ Chen Hsong Machines Are in Operation Worldwide.

They all use Chen Hsong.

High-speed Packaging Injection Molding Machine | Specifically Designed for Thin-Wall Packaging

SUPER PACK, SPEED PACK II

Maximum Injection Speed up to

500mm/s

SPEED PACK II

260-570T



SUPER PACK
270-430T

| SUPER PACK Core Value

- | Specifically designed for thin-wall product development
- | Brand new high-rigidity platen design, ensuring lifetime performance
- | Brand new high-performance alloy tie bar design, ensuring stable and worry-free operation under extreme working conditions
- | The system adopts an EtherCAT high-speed digital bus, resulting in higher anti-interference capability, High precision, and greater stability
- | More powerful drive system and higher injection pressure for easier molding
- | Nano far-infrared heating device as standard — energy-saving and eco-friendly
- | High-response hydraulic system for faster response, lower noise, and higher precision
- | Flared flange piping with no welded joints — preventing oil leakage under extreme conditions



*This data is test data, sourced from Chen Hsong Innovation Technology Center Laboratory

SUPER PACK CLAMPING UNIT

Tie-Bar

Optimized tie bar design for thin-wall packaging applications, for increased robustness and durability.

High Rigidity Platen

Effectively reduces stress, improves production stability, and extends service life.

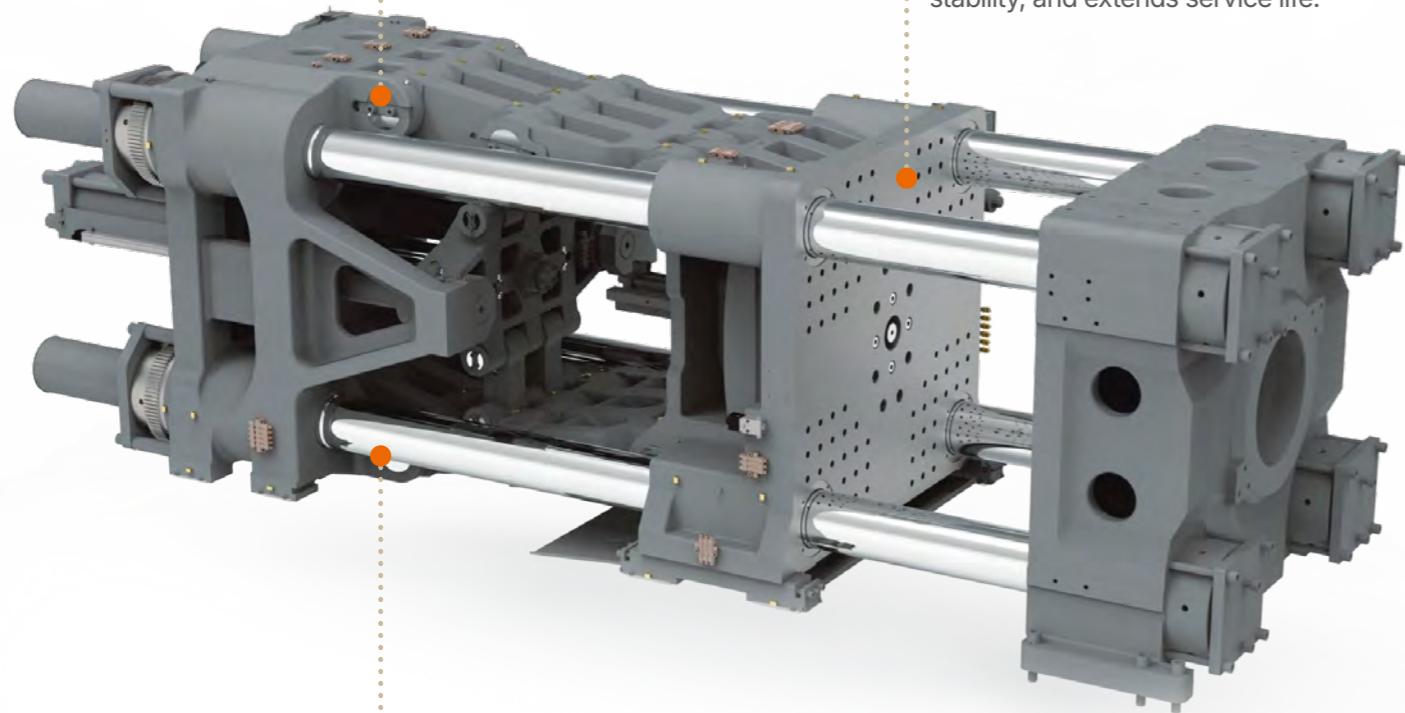

High-Performance Alloy Tie Bar

Made of alloy steel with optimized nut structure design, more suitable for thin-wall packaging injection molding applications, enhancing the tie bar's bearing capacity and service life, ensuring long-term stability and precision of the machine during injection molding.

Multi-set Air Blow Device and Pneumatic Sequence Control Device

Accelerates product removal, improves product quality, further shortens molding cycle, meeting more application requirements.

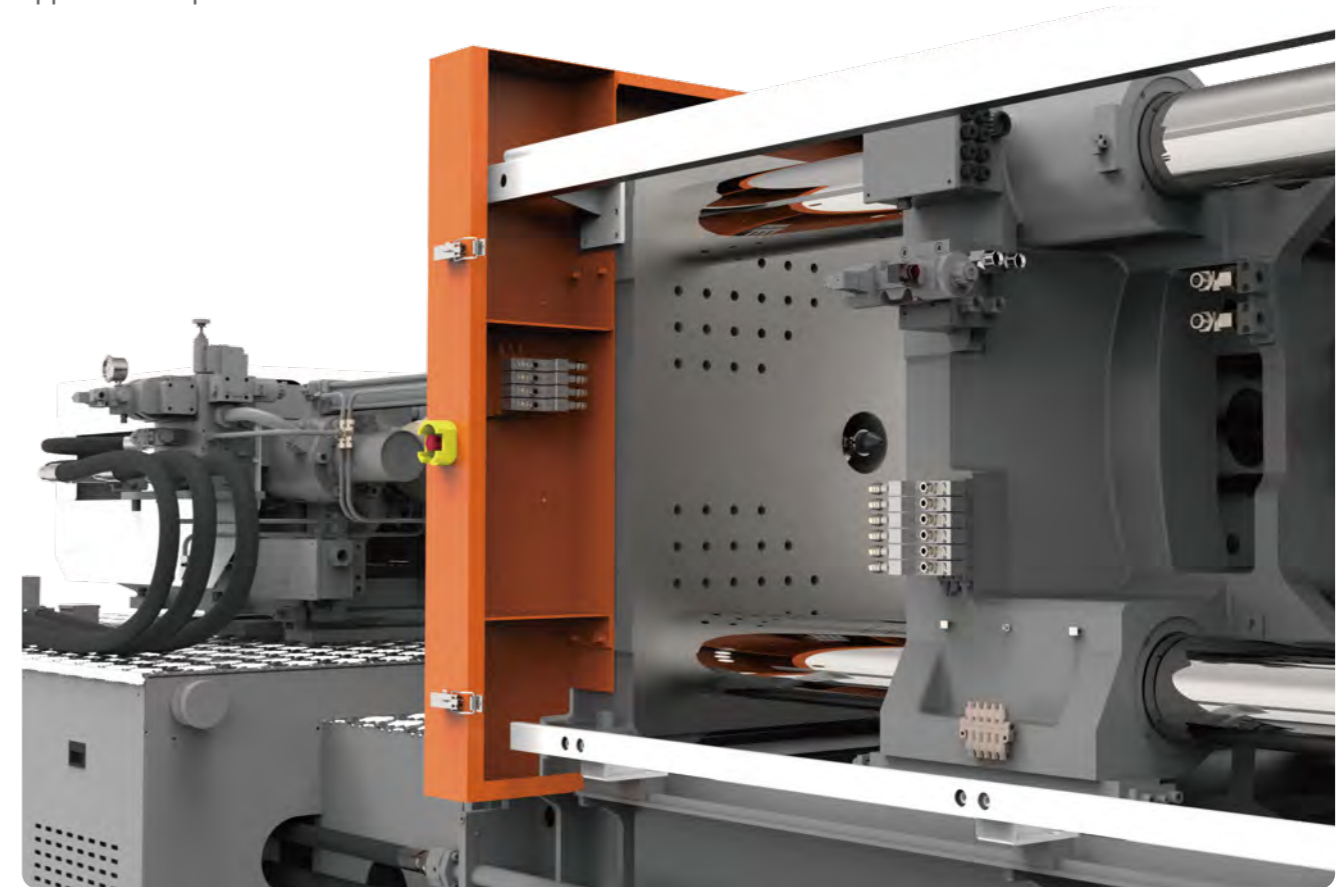

Centralized Clamping Pressure Transmission

The moving platen transmits clamping force through centralized pressure, and the clamping force in the forming process is evenly distributed on the mold surface, effectively preventing product flash.

Dedicated Mold Adjustment Motor

Built-in braking function, effectively ensures stability of continuous production.

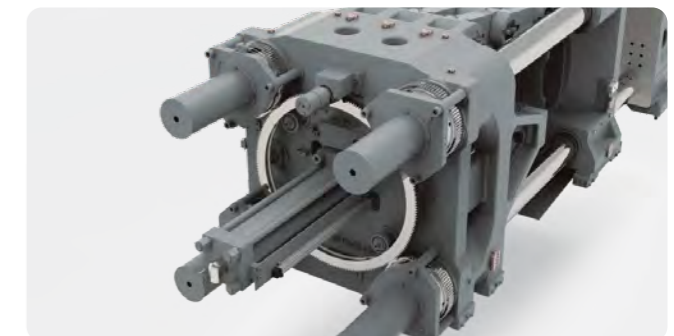
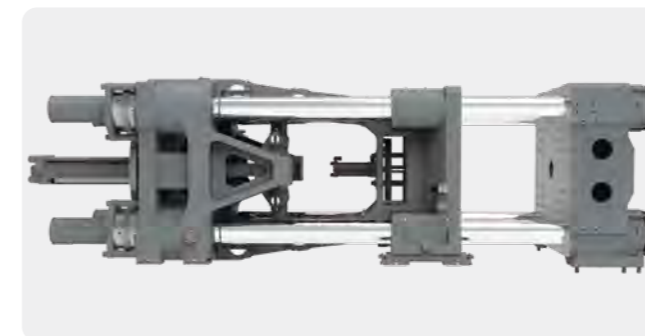

*This data is test data, sourced from Chen Hsong Innovation Technology Center Laboratory

SUPER PACK INJECTION UNIT

High-precision Linear Guide Rails
Achieves smoother injection movement

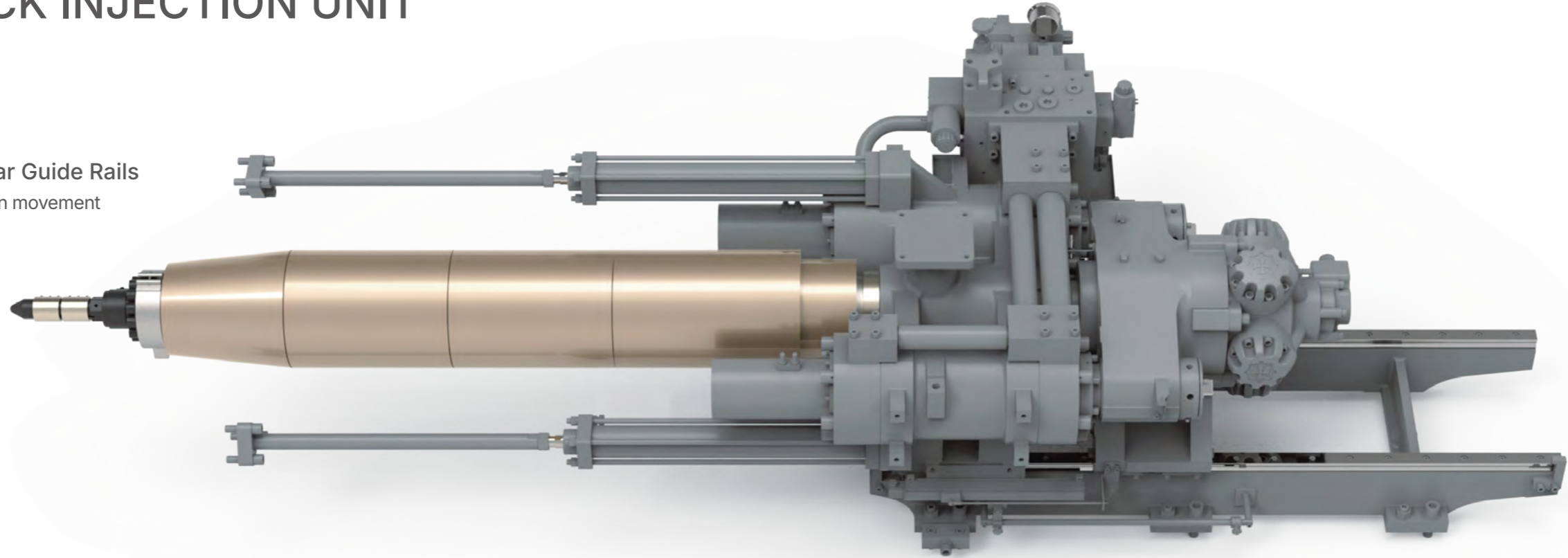

High Plasticizing Rate Screw
Specifically designed for raw materials in the thin-wall packaging industry



Nano Far-infrared Heating Device
Faster heating speed, better insulation effect, more energy-efficient and environmentally friendly

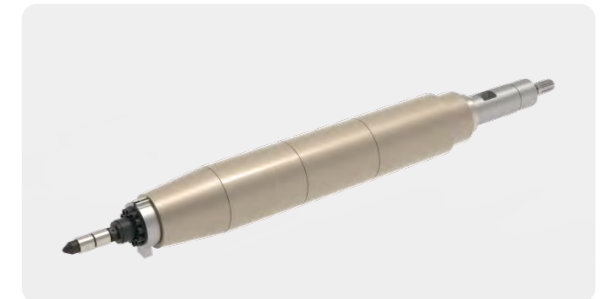

Balanced Dual Injection Carriage Cylinders
Based on high injection speed requirements, the injection unit's dual injection carriage cylinders are evenly stressed and more balanced



Magnetic Non-contact Linear Transducer
NO mechanical wear during high-speed motion, ensuring long-term high stability and extended service life

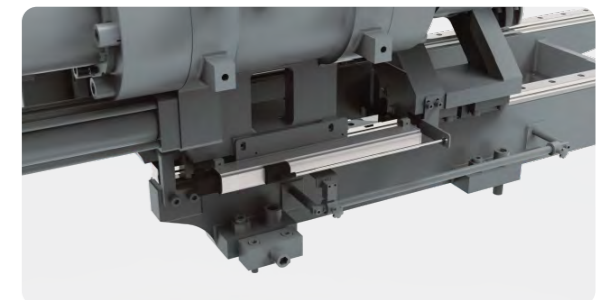

*This data is test data, sourced from Chen Hsong Innovation Technology Center Laboratory

SUPER PACK INJECTION UNIT

Flared flange piping, no welding on the machine's entire piping
Simple installation, strong sealing, effectively reducing the risk of oil leakage.

Mold Opening and Closing Servo Proportional Valve
Ensuring stable control during platen operation.

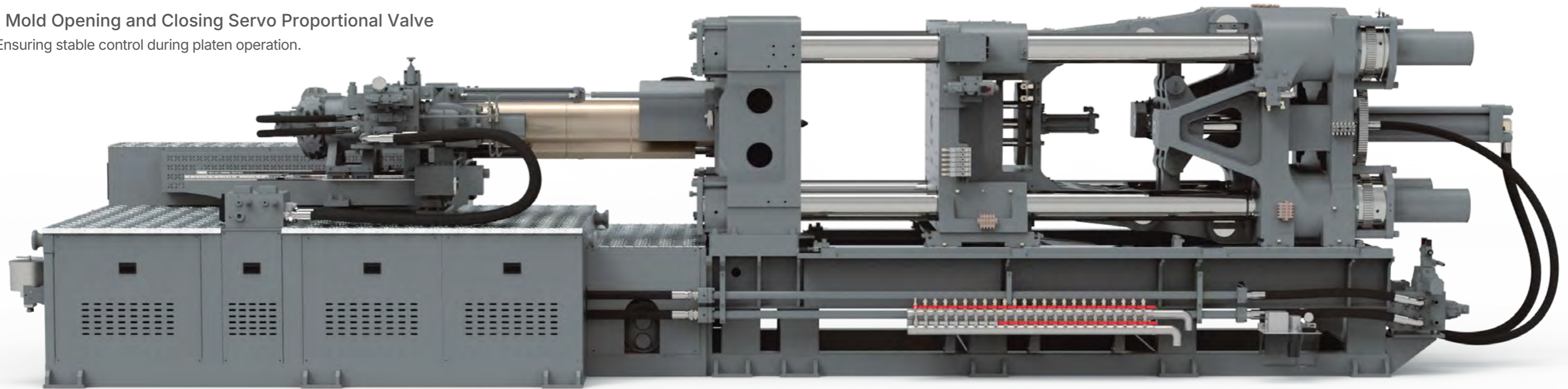

High-Response Servo Motor
High dynamic response, response time improved by 38.6%.

High-speed packaging machine dedicated oil pump
High-efficiency, low-noise internal gear pump, easily handles high-speed, high-pressure operating conditions.

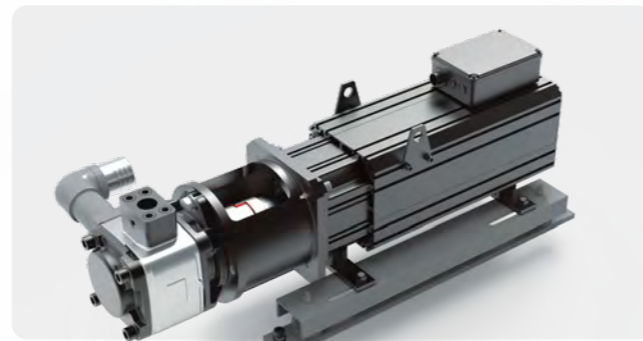

NAS Class 6 Hydraulic By-pass Filter
Further filters and cleans hydraulic oil, extending the service life of hydraulic components.

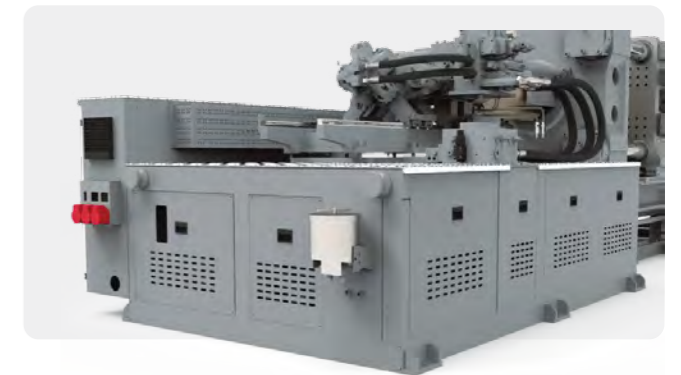

*This data is test data, sourced from Chen Hsong Innovation Technology Center Laboratory

SUPER PACK Electrical Control Unit



- | Integrated EtherCAT high-speed digital bus, integrated servo control function
- | Compliant with JIS and IEC standards
- | Integrated smart mold open/close function
- | Integrated smart plasticizing function

*This data is test data, sourced from Chen Hsong Innovation Technology Center Laboratory

SUPER PACK Other Qualities



Ultra-strong Rigid Frame

Overall strength increased by 50%, machine center of gravity lowered by up to 7.8%, resulting in smoother operation and ensuring good product yield.

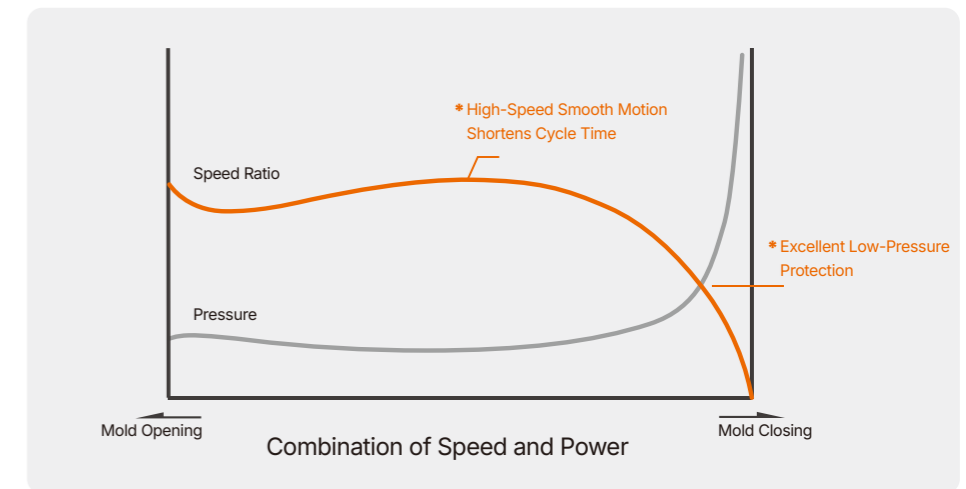

Precision Hydraulic Technology™

Through high-precision algorithms and patented technology, matched with the toggle structure, it precisely controls the hydraulic system to achieve high efficiency, stability, and safety in the production process.

SUPER PACK | Technical Parameters

Technical Parameters	UNIT	SUPER PACK 270	SUPER PACK 330	SUPER PACK 380	SUPER PACK 430				
Injection Unit									
Screw Diameter	mm	31	36	46	52	52	60	52	60
Screw L/D Ratio	/	24.4	21	26	26	26	26	26	26
Theoretical Injection Capacity	cm ³	135	183	432	552	424	565	424	565
Injection Shot Weight (PS)	g	122	166	393	502	385	514	385	514
Injection Pressure (Max.)	Mpa	254.8	189	226.3	177.2	226.1	169.9	226.1	169.9
Injection Rate (Max.)	cm ³ /s	377	508	830	1061	1061	1413	1061	1413
Injection Speed (Max.)	mm/s	500	500	500	500	500	500	500	500
Injection Stroke (Max.)	mm	180	180	260	260	200	200	200	200
Plasticizing Rate (Max.)	g/s	25	31	45	62.9	62.9	90	62.9	90
Screw Speed (Max.)	rpm	300	300	300	300	300	300	300	300
Nozzle Contact Force (Max.)	kN	42	42	67	67	67	67	67	67
Nozzle Stroke (Max.)	mm	275	275	380	380	500	500	500	500
CLAMPING UNIT									
Clamping Force (Max.)	kN	2700	2700	3300	3300	3800	3800	4300	4300
Mold Opening Stroke (Max.)	mm	560	560	600	600	640	640	650	650
Platen Dimensions (H×V)	mm	930X920	930X920	1020X980	1020X980	1070X1040	1070X1040	1140X1080	1140X1080
Distance Between Tie Bars (H×V)	mm	580X570	580X570	640X600	640X600	670X640	670X640	720X660	720X660
Mold Thickness (Min.-Max.)	mm	220-600	220-600	250-650	250-650	270-670	270-670	300-700	300-700
Daylight (Max.)	mm	1160	1160	1250	1250	1310	1310	1350	1350
Ejector Force (Max.)	kN	77	77	77	77	77	77	77	77
Ejector Stroke (Max.)	mm	100	100	100	100	100	100	100	100
Number of Ejectors	PCS	7	7	7	7	7	7	7	7
Locating Ring Diameter	mm	125	125	125	125	125	125	125	125
OTHERS									
System Pressure	Mpa	175	175	190	190	190	190	190	190
Motor Power (Rated)	kW	40	40	40+40	40+40	51+51	51+51	51+51	51+51
Barrel Heating Power (Max.)	kW	8	8	22	22	22	26	22	26
Rated Current (Max.)	A	89	89	185.3	185.3	227.1	233.1	227.1	233.1
Temperature Control Zones	Zone	3+1	3+1	4+1	4+1	4+1	4+1	4+1	4+1
Machine Dimensions (L×W×H)	m	6.3X1.8X2.3	6.3X1.8X2.3	6.8X2.0X2.3	6.8X2.0X2.3	7.9X2.2X2.3	7.9X2.2X2.3	8.0X2.2X2.2	8.0X2.2X2.2
Oil Tank Capacity	L	380	380	480	480	600	600	615	615
Machine Weight	Ton	10.23	10.23	14.03	14.03	16.6	16.6	19.8	19.8

*The above technical parameters are for reference only and may vary under different conditions. Our company continuously improves products and reserves the right to change product specifications and parameters without prior notice. The final interpretation right of this specification sheet belongs to our company.

SUPER PACK | Standard & Optional Configuration

Note: ● = Standard, ○ = Optional, × = Not available.

Specification	SUPER PACK 270	SUPER PACK 330	SUPER PACK 380	SUPER PACK 430	
INJECTION UNIT	1.Packaging Industry Plasticizing Components	●	●	●	●
	2.Low-Resistance Nozzle	●	●	●	●
	3.Nano Far-Infrared Heater	●	●	●	●
	4.Non-Contact high-Response Linear Transducer	●	●	●	●
	5.Manual Back Pressure	●	●	●	●
	6.Parallel Plasticizing	○	●	●	●
	7.Hopper	○	○	○	○
	8.Hopper Slider	○	○	○	○
	9.Electric Plasticizing	○	○	○	○
	10.Linear Transducer For Injection carriage	○	○	○	○

Specification	SUPERPACK270	SUPERPACK330	SUPERPACK380	SUPERPACK430	
HYDRAULICS	1.High-Speed Servo Drive System	●	●	●	●
	2.High-speed Hydraulic Control Unit	●	●	●	●
	3.Servo Proportional Valve for mold Open/Close	●	●	●	●
	4.High-Efficiency Hydraulic Oil Cooler	●	●	●	●
	5.Mold Cooling Water Manifold	12 set	16 set	24 set	24 set
	6.Hydraulic Oil Temperature Control	○	○	○	○
	7.Oil Level Indicator And Alarm	○	○	○	○
	8.Manual Lubrication (Additional)	○	○	○	○
	9.Digital Back Pressure Control	○	○	○	○
	10.Glass Tube Cooling Flowmeter	○	○	○	○
	11.High Steady-State Hydraulic Control	○	○	○	○

Specification	SUPER PACK 270	SUPER PACK 330	SUPER PACK 380	SUPER PACK 430	
CLAMPING UNIT	1.High-Rigidity Platen (With Clamping Holes)	●	●	●	●
	2.High-Rigidity Tie Bars	●	●	●	●
	3.High-Rigidity Crankshaft Toggle	●	●	●	●
	4.Mold Height Adjustment Motor With Brake	●	●	●	●
	5Automatic Lubrication System For Toggle	●	●	●	●
	6.Front and Back Doors Aligned Flush With The Door Rails	●	●	●	●
	7. Safety Door With Hydraulic And Electric Interlock Protection	●	●	●	●
	8. T-Slot Platen	○	○	○	○
	9.T-Slot Platen With Clamping Holes	○	○	○	○
	10.SPI Platen	○	○	○	○
	11.Mold Insulation Plate	○	○	○	○
	12.Mechanical Safety Lock	○	○	○	○
	13.Synchronous Ejector Device	○	○	○	○
	14.Enlarged Mold Capacity Device	○	○	○	○

Specification	SUPERPACK270	SUPERPACK330	SUPERPACK380	SUPERPACK430	
CONTROLLER	1.15-Inch High-Response Touchscreen Controller	●	●	●	●
	2.Robot Interface Box	●	●	●	●
	3.PID Temperature Control System	●	●	●	●
	4.Screw RPM Display	●	●	●	●
	5.Cold Material Start-Up Protection	●	●	●	●
	6.Temperature Sensing Disconnection Monitoring	●	●	●	●
	7Automatic Mold Height And Clamping Force Adjustment	●	●	●	●
	8.Three-color LED Warning Light	●	●	●	●
	9.220V / 10A Waterproof 3-Hole Socket	1 set	1 set	1 set	1 set
	10.220V / 16A Waterproof 5-Hole Socket	1 set	1 set	1 set	1 set
	11.380V/32A Waterproof 5-Hole Socket	2 set	2 set	2 set	2 set
	12. Air Blowing Device	5 set	5 set	6 set	6 set
	13.Feed Inlet Temperature Closed-Loop Control Device	○	○	○	○
	14.EU12 Robot Interface (Euomap)	○	○	○	○
	15.EU67 Robot Interface (Euomap)	○	○	○	○
	16.Mega Router Network Gateway	○	○	○	○
	17.Additional Socket Types And Quantity	○	○	○	○
	18.Change Power Supply Voltage	○	○	○	○
	19.AI Mold Adjustment Assistant	○	○	○	○

SUPER PACK | Platen & Dimension Drawing

SUPER PACK 270

Platen Dimensions

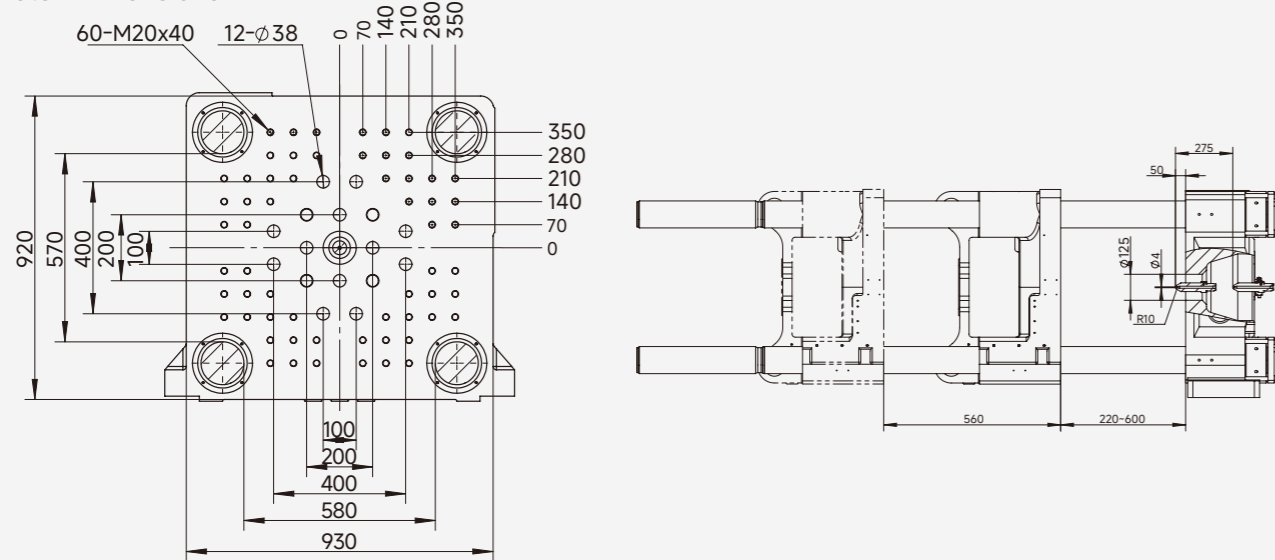

Machine Dimensions (LxWxH)

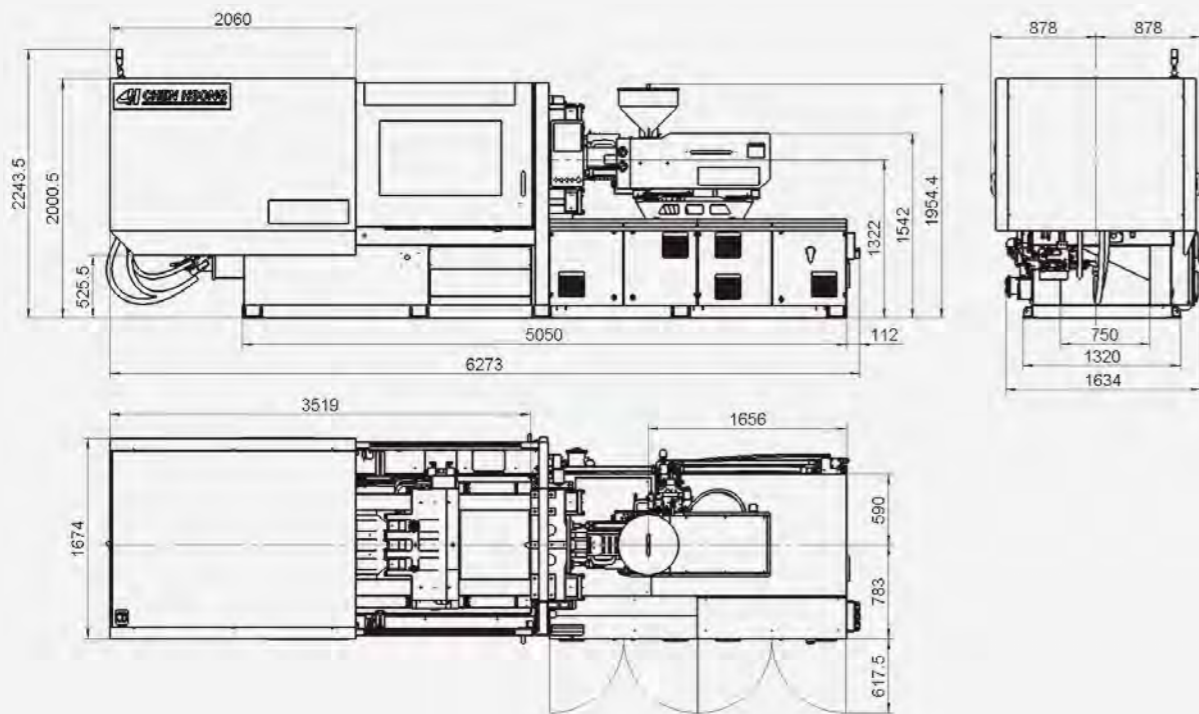

SUPER PACK 330

Platen Dimensions

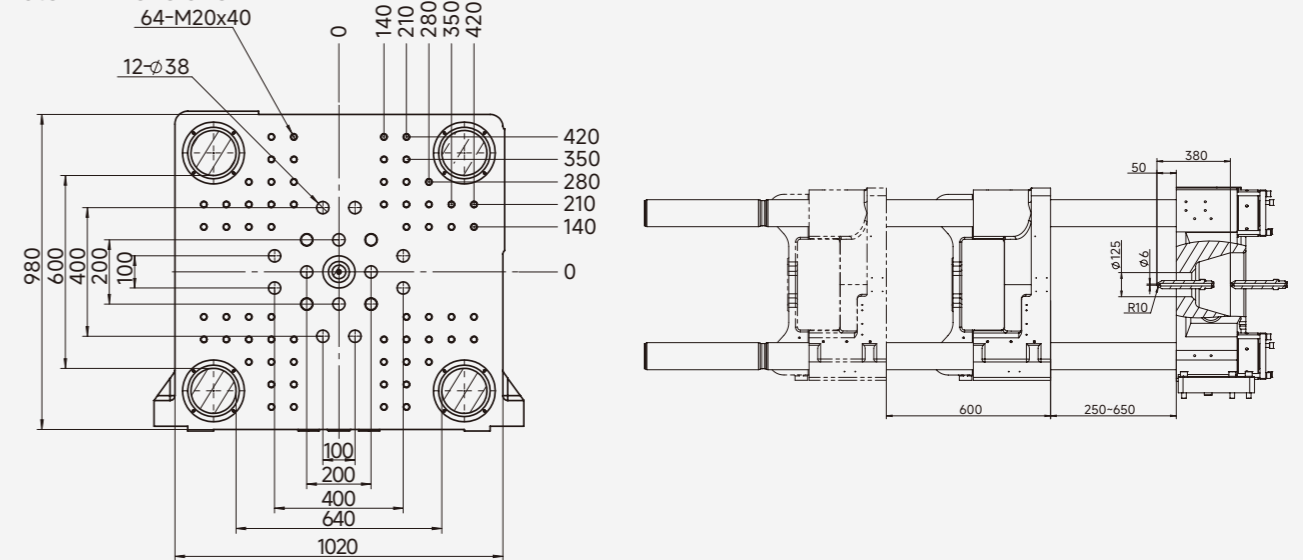

Machine Dimensions (LxWxH)

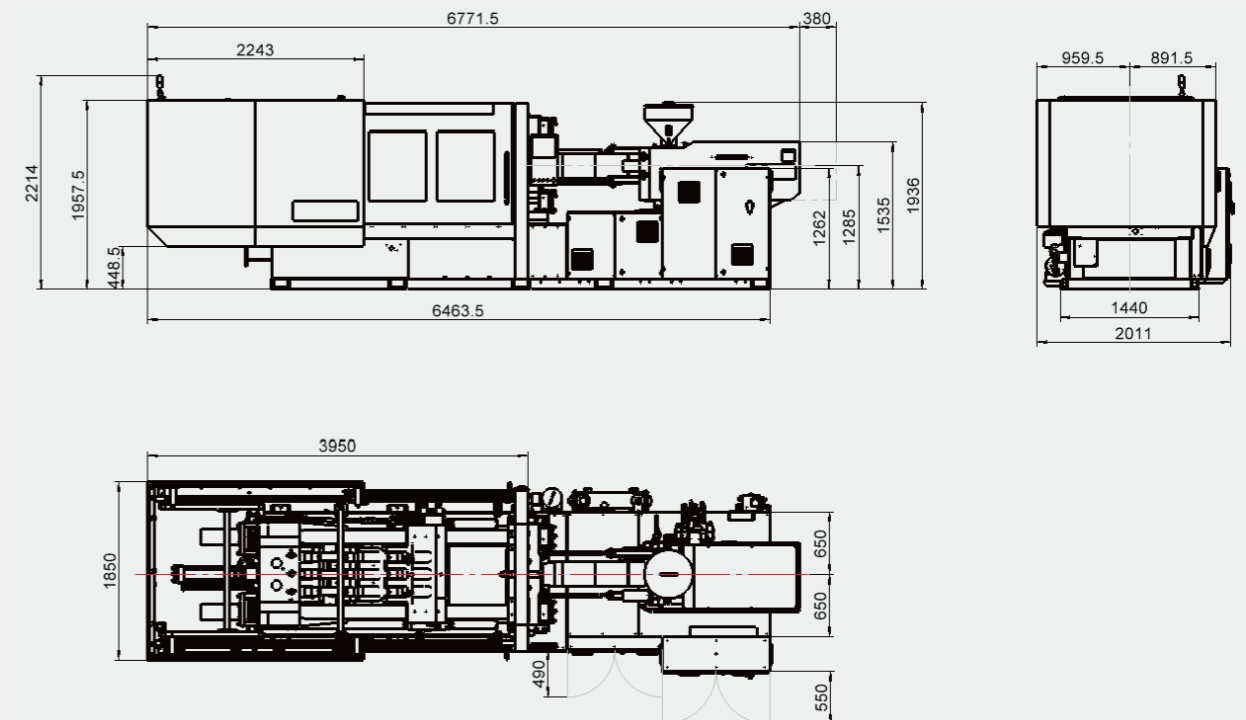

SUPER PACK | Platen & Dimension Drawing

SUPER PACK 380

Platen Dimensions

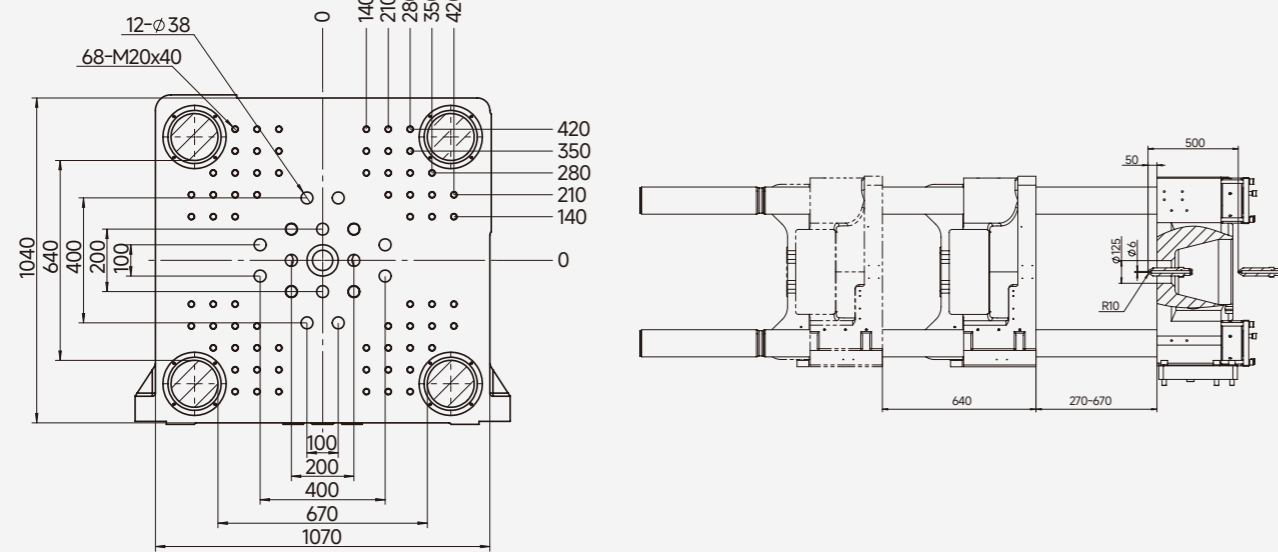

Machine Dimensions (LxWxH)

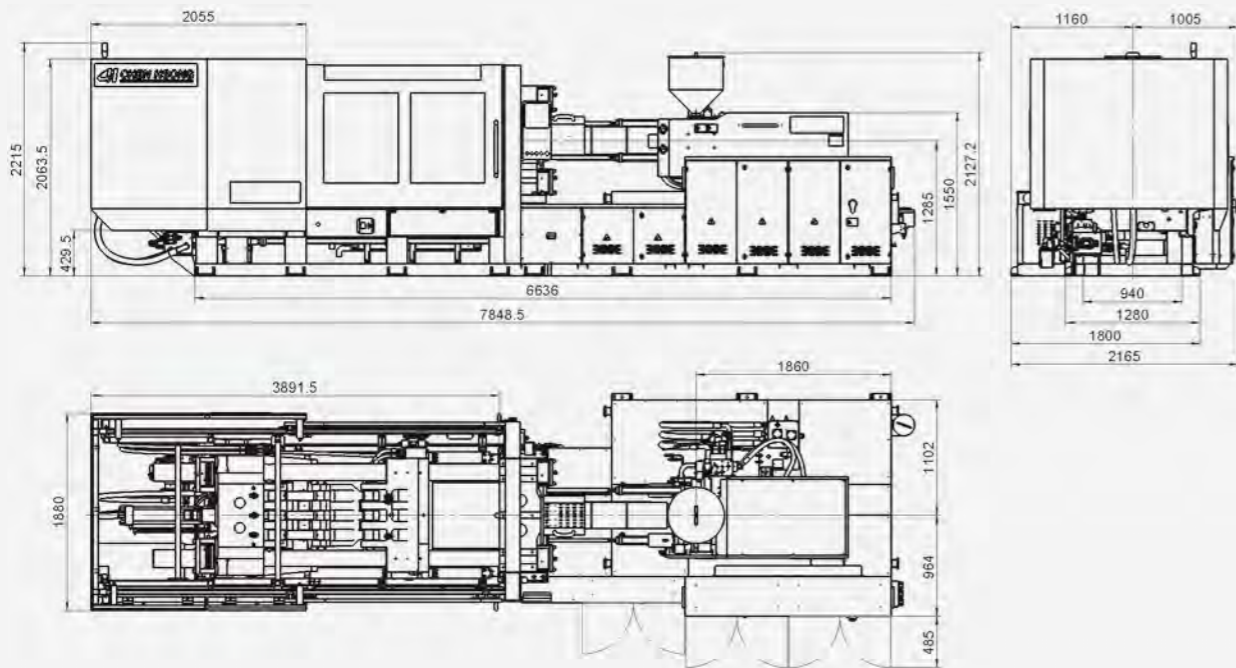

SUPER PACK 430

Platen Dimensions

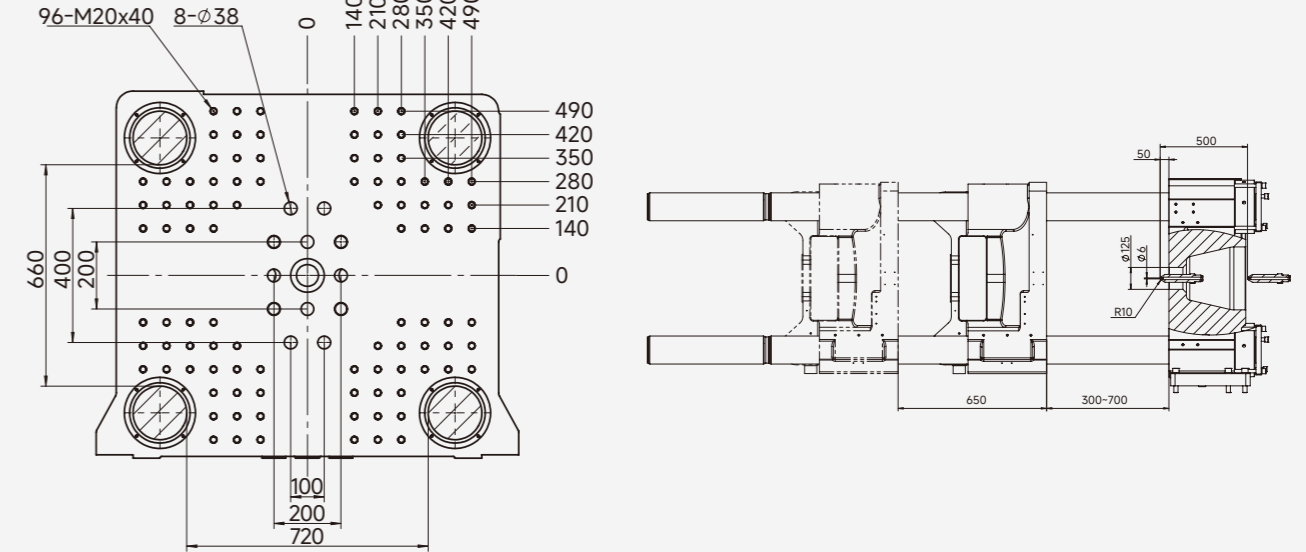

Machine Dimensions (LxWxH)

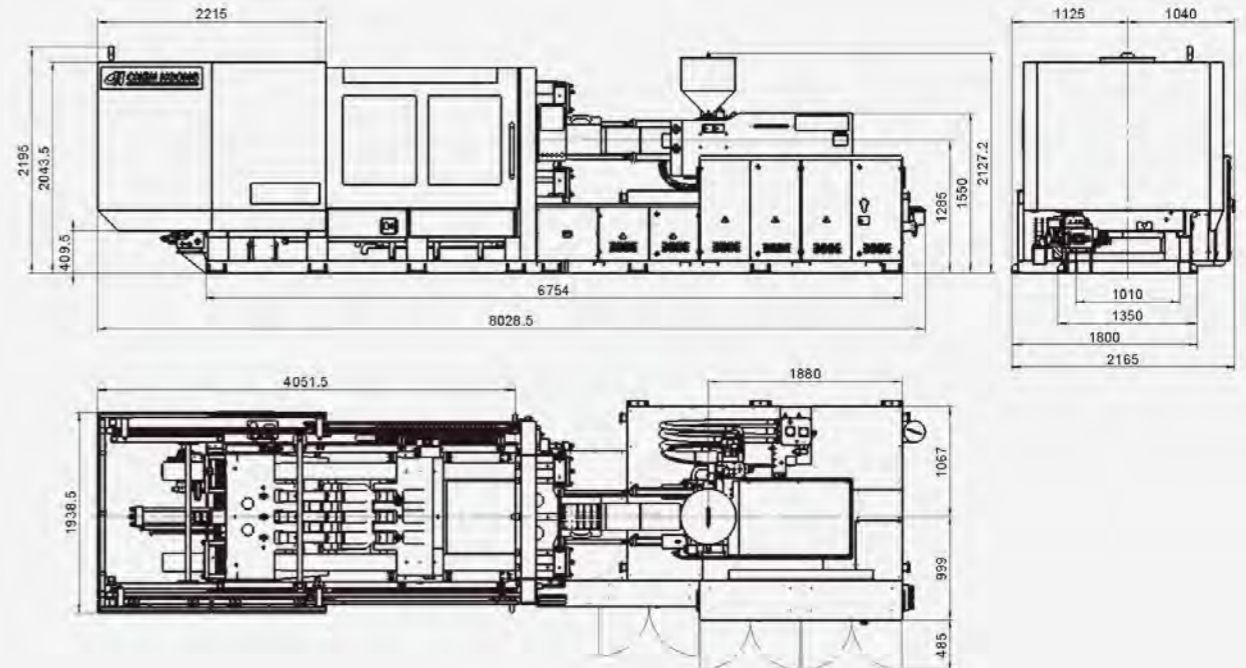

SUPER PACK | Robot Arm Installation Drawing

SUPER PACK 270

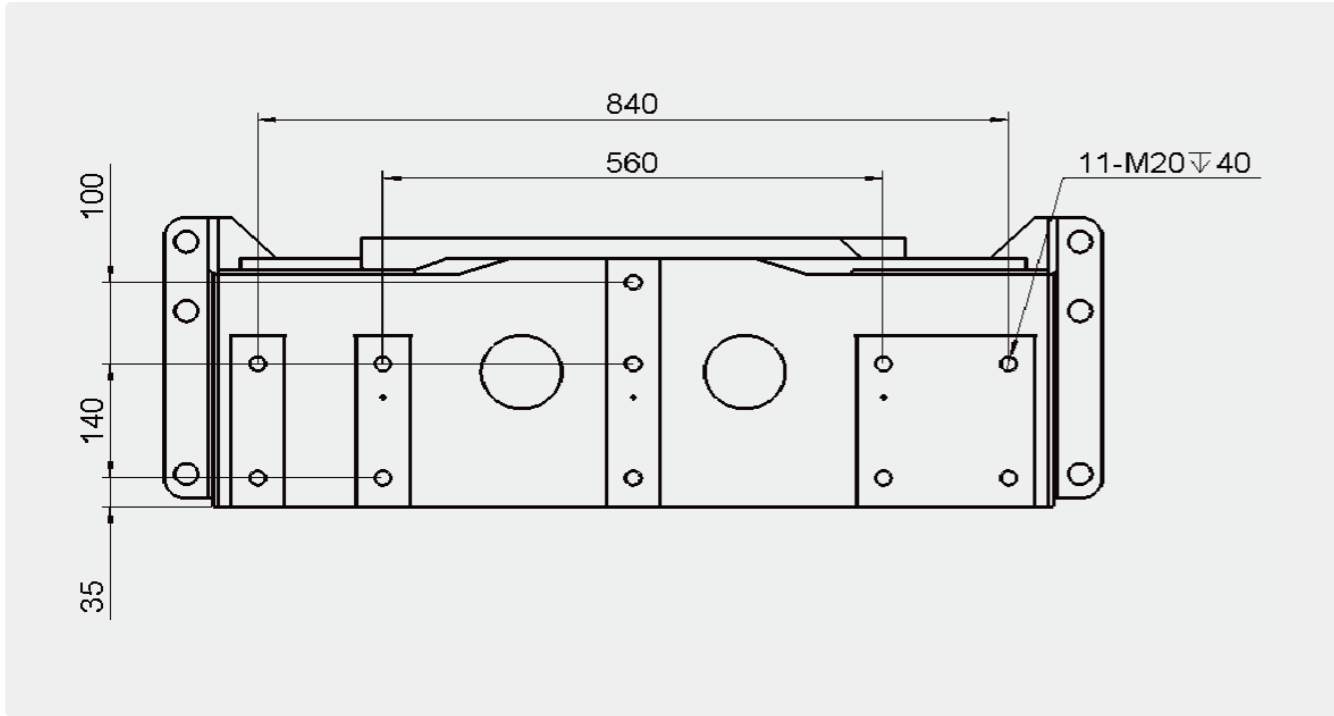

SUPER PACK 380

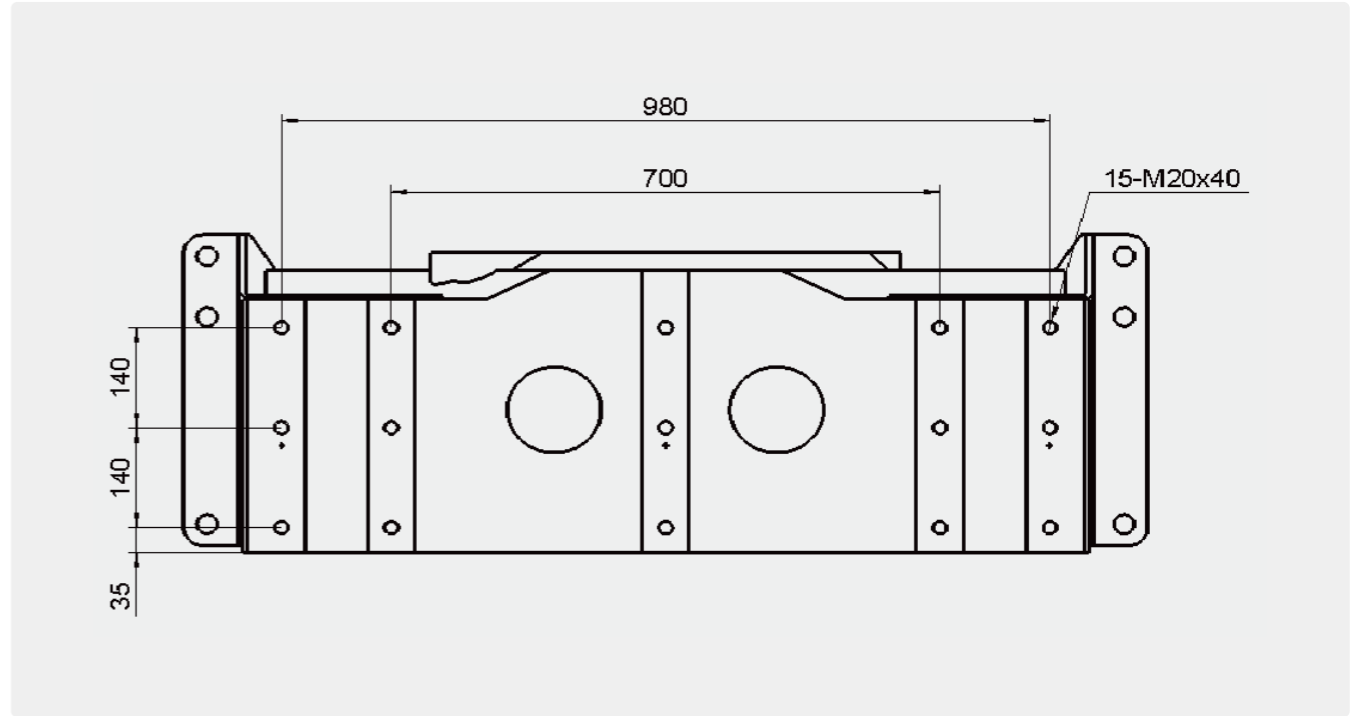

SUPER PACK 330

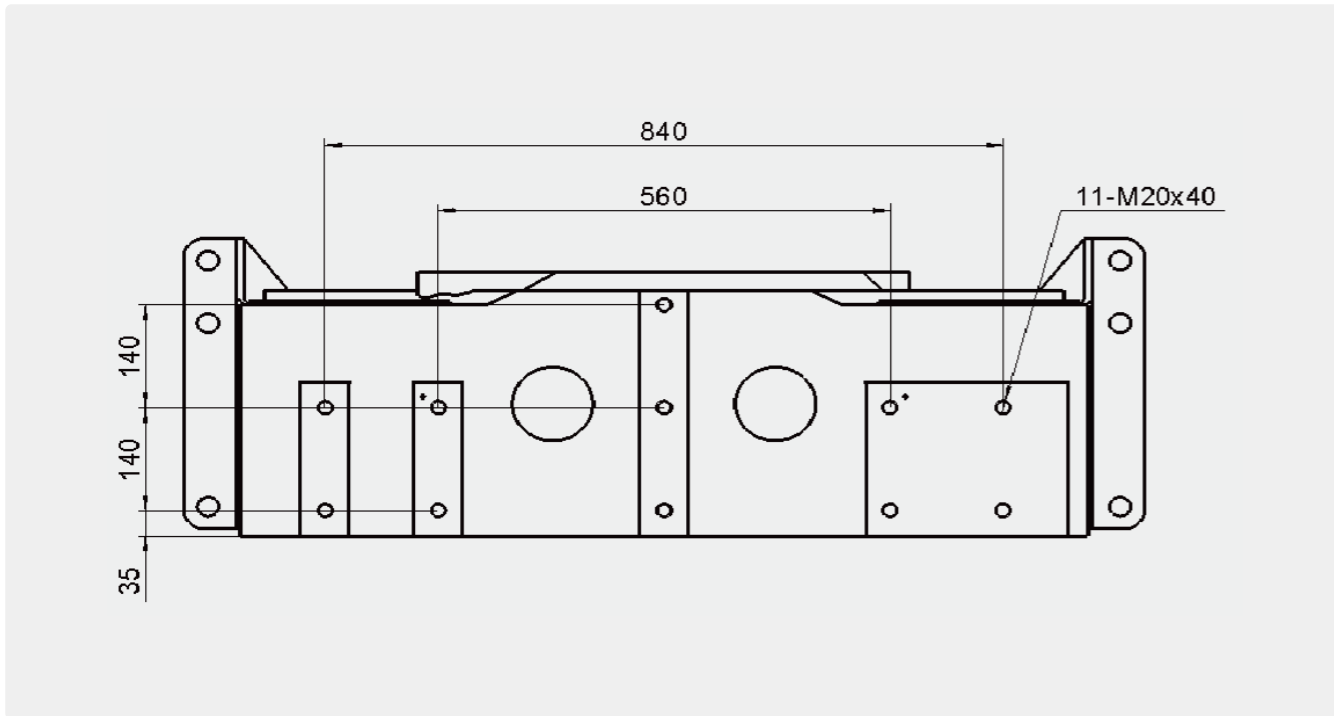

SUPER PACK 430

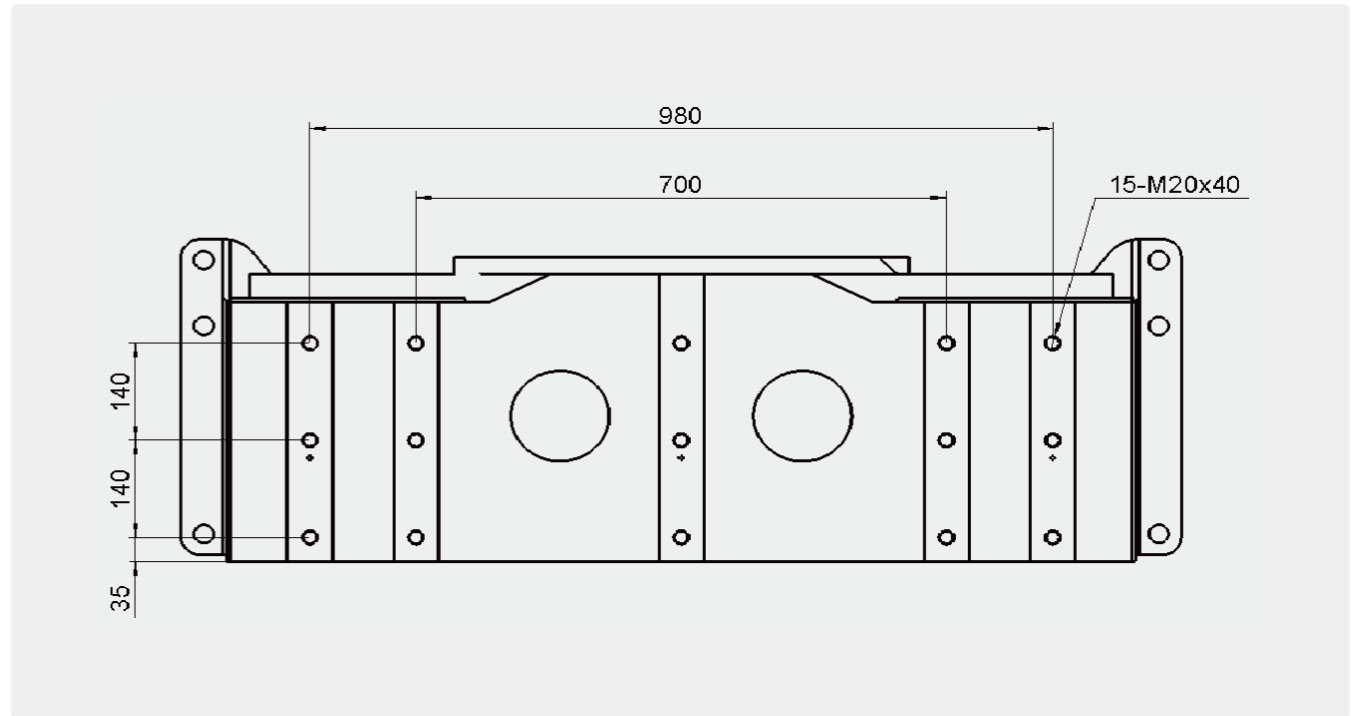

iChen™ Smart Family

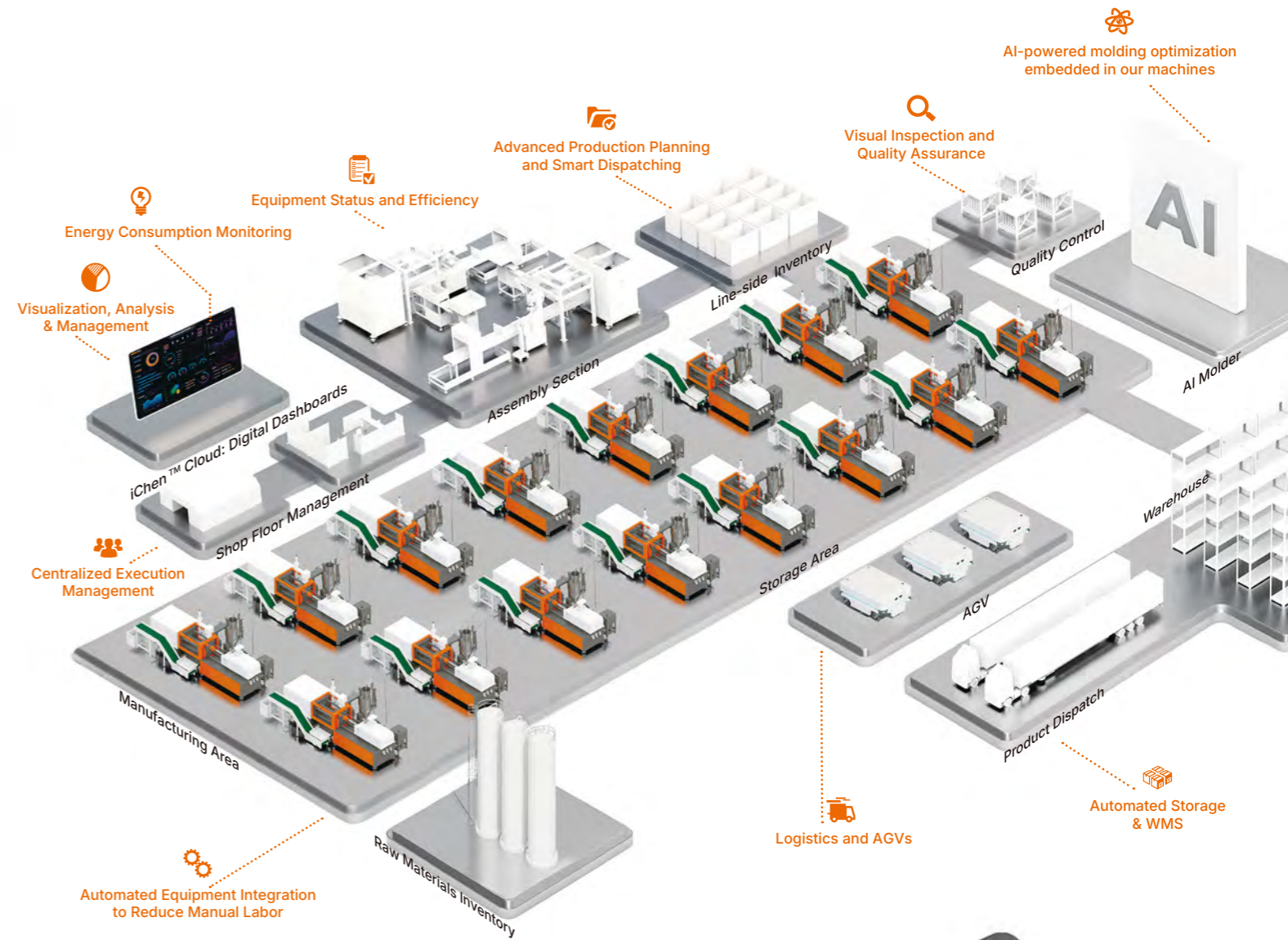
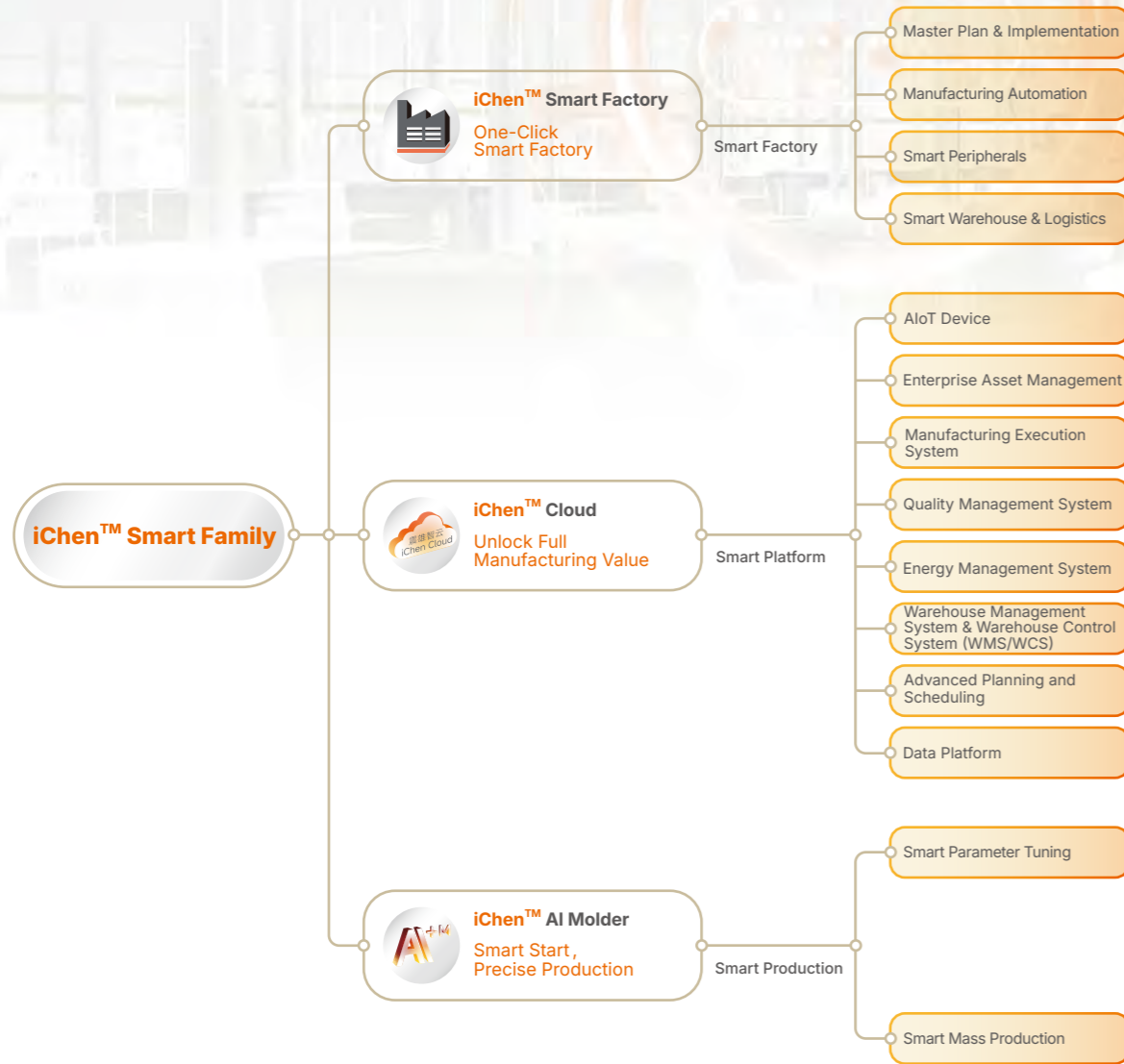

iChen™ Smart Factory

One-Click Smart Factory

iChen™ Smart Factory delivers plant-wide, end-to-end line engineering and integration. Covering planning and design, auxiliary-system configuration, automation, smart peripherals, and warehouse and logistics setup, we integrate the entire production chain and deliver complete turnkey factory projects.

iChen™ Cloud

Unlock Full Manufacturing Value

iChen™ Cloud is a Smart Manufacturing Operations Management Platform covering Artificial Intelligence Internet of Things (AIoT), Enterprise Asset Management (EAM), Manufacturing Execution System (MES), Quality Management System (QMS), Energy Management System (EMS), Warehouse Management System & Warehouse Control System (WMS/WCS), Advanced Planning and Scheduling (APS), and the Data Platform. Together, these enable end-to-end digital control with real-time visibility and executive dashboards for faster, data-driven decisions.

iChen™ AI Molder

Smart Start, Precise Production

iChen™ AI Molder is an AI-driven injection-molding solution developed by Chen Hsong Group in collaboration with industry-academia research teams. It integrates AI with injection-molding process expertise to recommend and optimize parameters, stabilize mass production, reduce defects, and increase yield.



iChen™ Smart Family



Dedicated to Thin-Wall Packaging

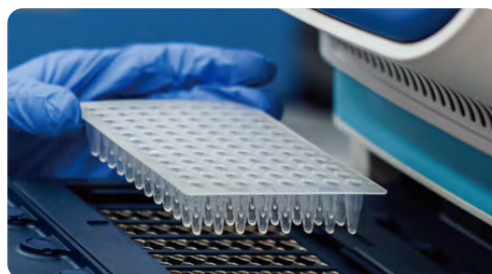

Without realizing it, you will find products made by Chen Hsong machines everywhere.
That is the charm of injection moulding machines.





“What our customers need is what we deliver!”