

# iChen™ Smart Family

Intelligent Solutions

- Empower Customers to Achieve More -



YouTube



Facebook



LinkedIn

## CHEN HSONG

Add.: Unit 2001, 20th Floor, Citicorp  
Centre, 18 Whitfield Road,  
Hong Kong

Tel.: +852 2665-3888 | 2665-3222

Email: [mr@chenhsong.com](mailto:mr@chenhsong.com)

Web.: [www.chenhsong.com](http://www.chenhsong.com)



# iChen™ Smart Family

With nearly 70 years of manufacturing expertise, we empower global customers to accelerate their transformation.

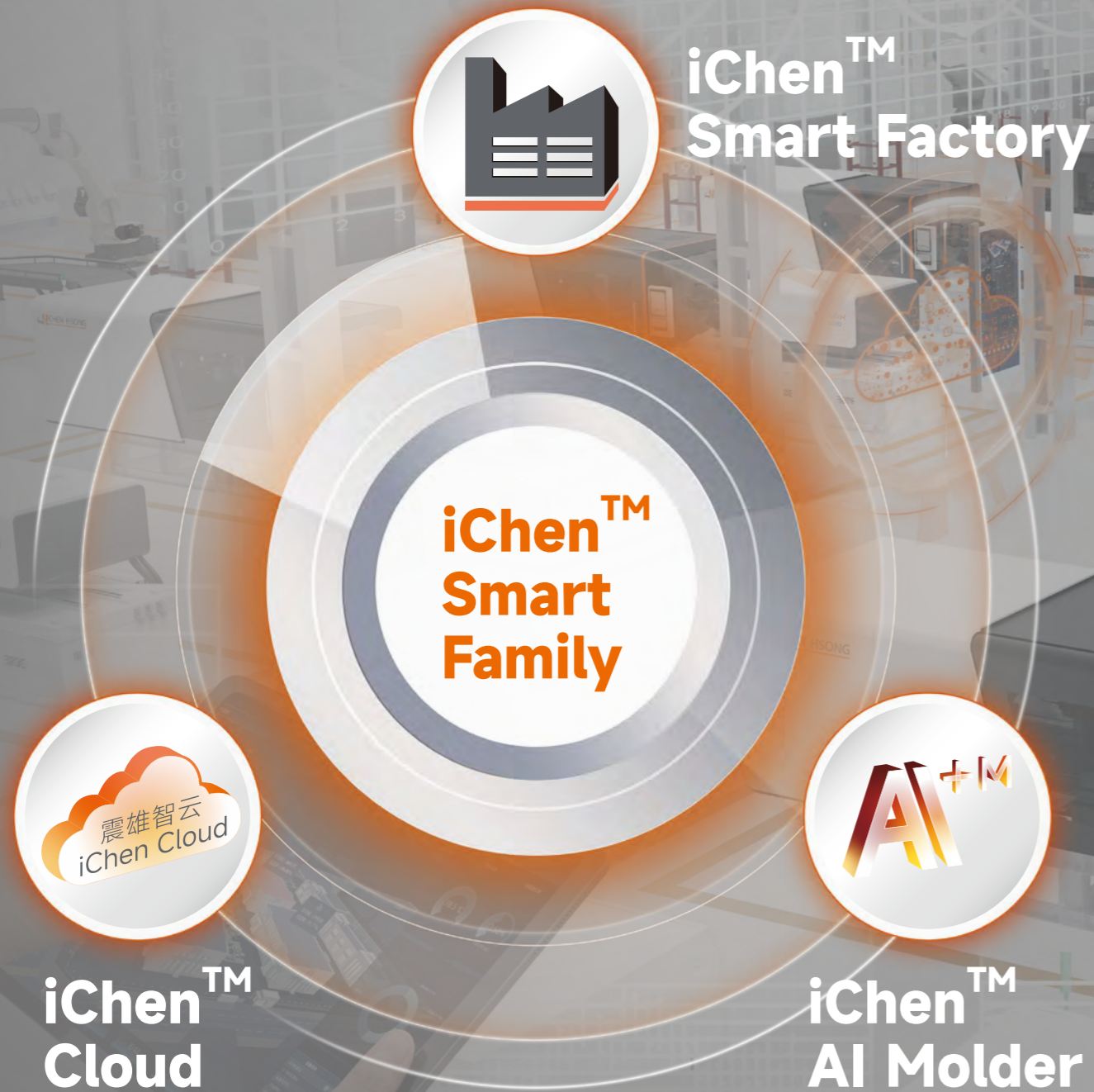

Leveraging over 20 years of intelligent platform development expertise, Chen Hsong has established the iChen™ Smart Family portfolio. This includes our self-developed iChen™ Cloud Manufacturing Operations Platform, the iChen™ Smart Factory intelligent production line implementation solution, and the AI Molder intelligent injection molding assistant. Together, our solutions provide a comprehensive, repeatable, and cost-effective path to smart-manufacturing transformation.



# iChen™ Smart Family

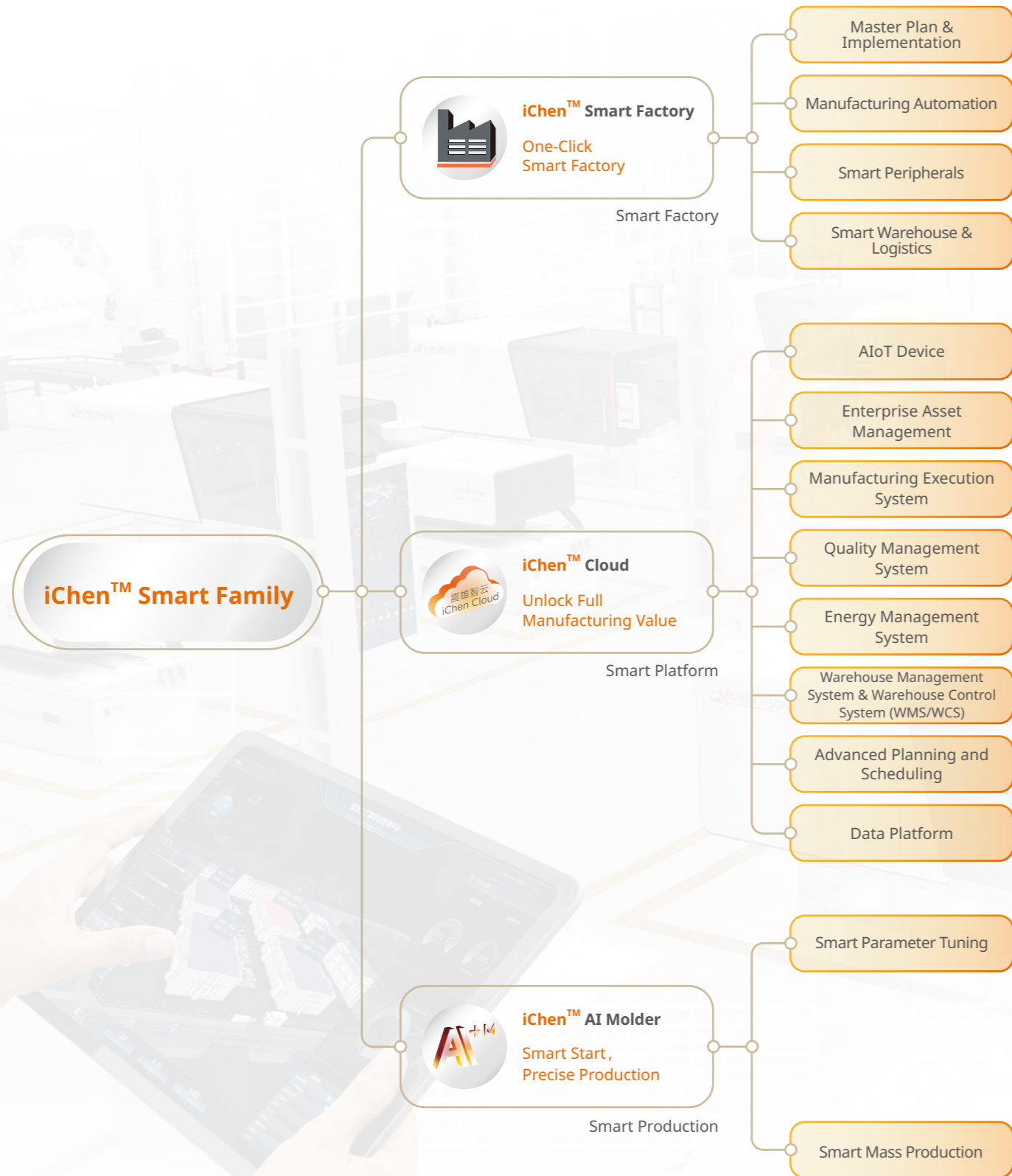

# iChen™ Smart Family

## iChen™ Smart Factory

### One-Click Smart Factory

iChen™ Smart Factory delivers plant-wide, end-to-end line engineering and integration. Covering planning and design, auxiliary-system configuration, automation, smart peripherals, and warehouse and logistics setup, we integrate the entire production chain and deliver complete turnkey factory projects.

## iChen™ Cloud

### Unlock Full Manufacturing Value

iChen™ Cloud is a Smart Manufacturing Operations Management Platform covering Artificial Intelligence Internet of Things (AIoT), Enterprise Asset Management (EAM), Manufacturing Execution System (MES), Quality Management System (QMS), Energy Management System (EMS), Warehouse Management System & Warehouse Control System (WMS/WCS), Advanced Planning and Scheduling (APS), and the Data Platform. Together, these enable end-to-end digital control with real-time visibility and executive dashboards for faster, data-driven decisions.

## iChen™ AI Molder

### Smart Start, Precise Production

iChen™ AI Molder is an AI-driven injection-molding solution developed by Chen Hsong Group in collaboration with industry-academia research teams. It integrates AI with injection-molding process expertise to recommend and optimize parameters, stabilize mass production, reduce defects, and increase yield.

# iChen™ Smart Family

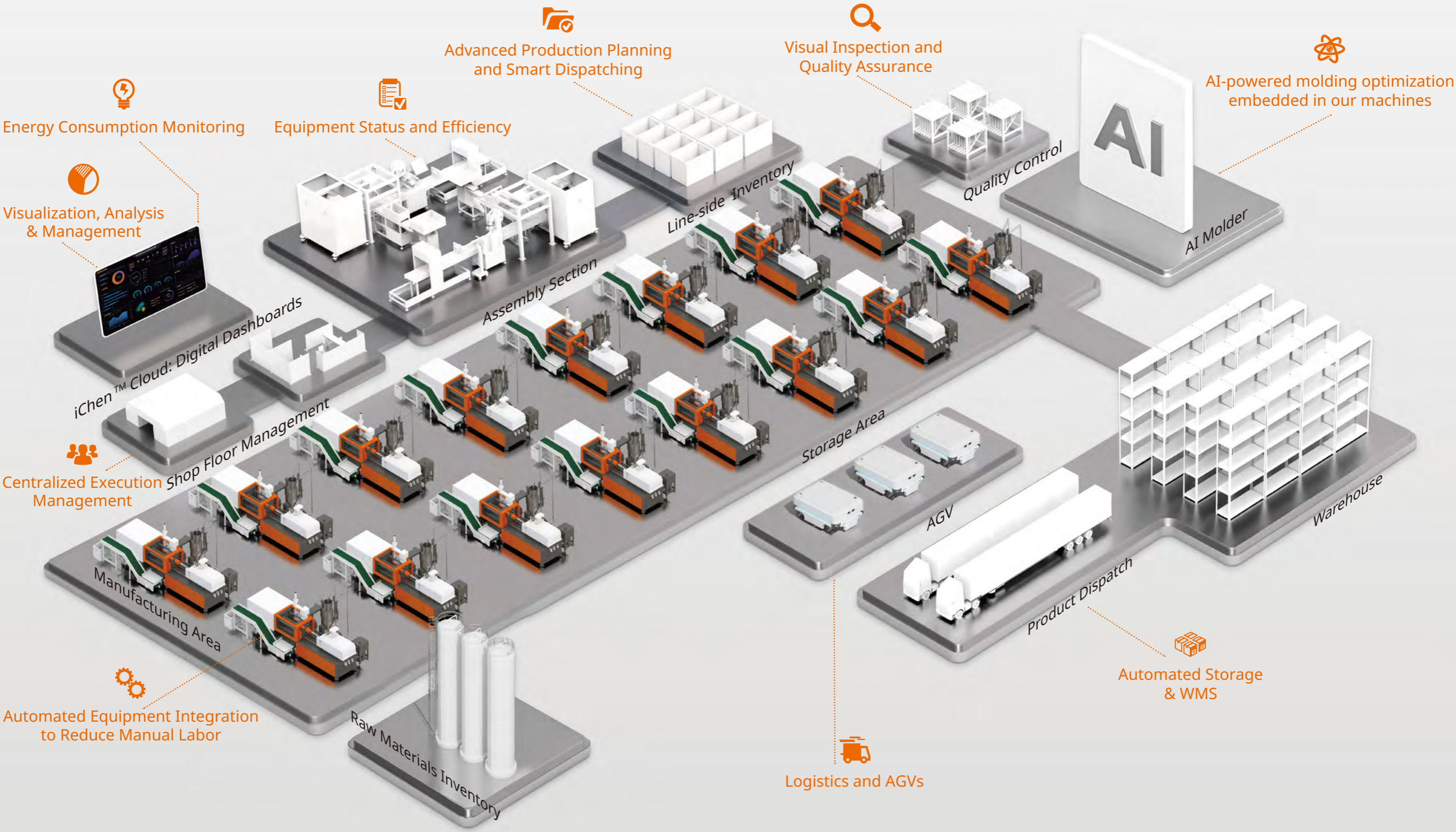

# iChen™ Smart Factory

## One-Click Smart Factory

iChen™ Smart Factory delivers plant-wide, end-to-end line engineering and integration. Covering planning and design, auxiliary-system configuration, automation, smart peripherals, and warehouse and logistics setup, we integrate the entire production chain and deliver complete turnkey factory projects.



Pictures are for reference only, subject to the actual interface.

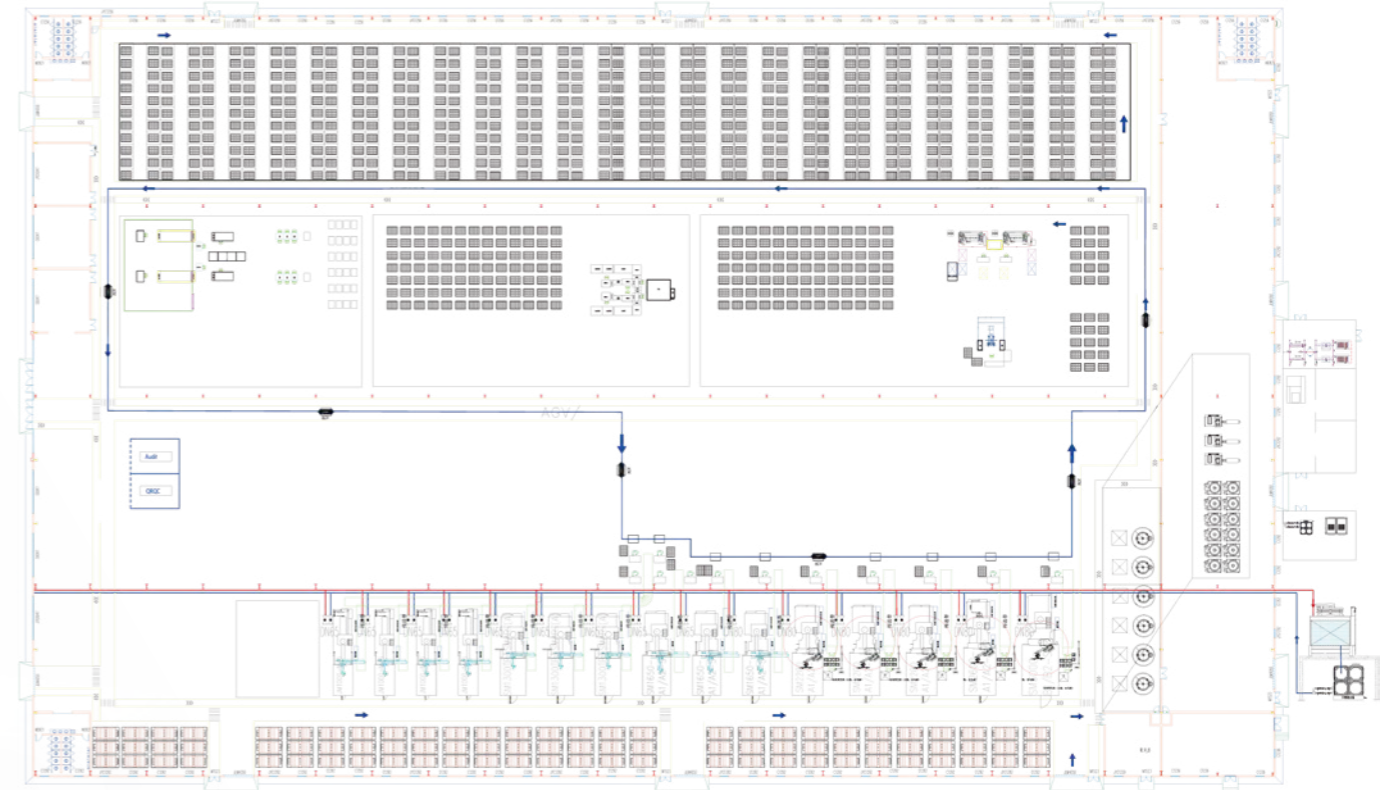

The above illustrates a 2023 project in the new energy automotive parts industry, for which CHEN HSONG deployed a total of 15 two-platen injection molding machines (ranging from 1000T to 3000T).

**1** End-to-End Quality Traceability, built into the system from day one.

**2** Higher Overall Efficiency, driven by lean line design.

**3** Tighter Control of Operating Costs, through system-level optimization.

**4** Data-Driven Decision-Making, built on a unified data platform.

## Automated PET Preform Injection Molding Solution

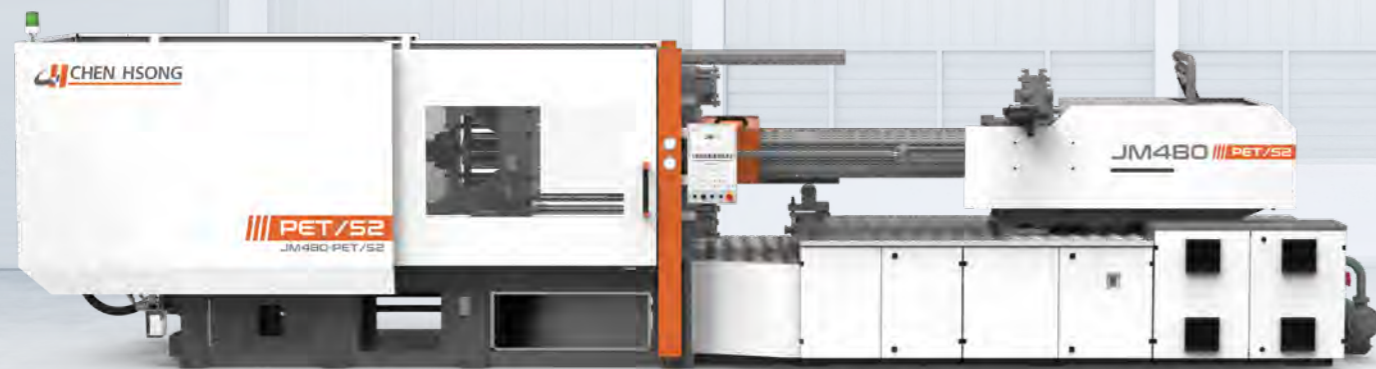

**Injection Molding Machine:** JM480-PET/S2

**Cavities:** 96

**Material:** PET

**Cycle Time:** 10 seconds

**Weight:** 16.5g

**Automated Handling Process for Side-Gated Preforms:** The process begins with the first injection molding cycle. A horizontal 2-axis robot then extracts the preforms and cools them within its clamp. After cooling, the robot places the finished preforms onto an output conveyor for transport.

**Workstations:** 2 to 3

### Products:

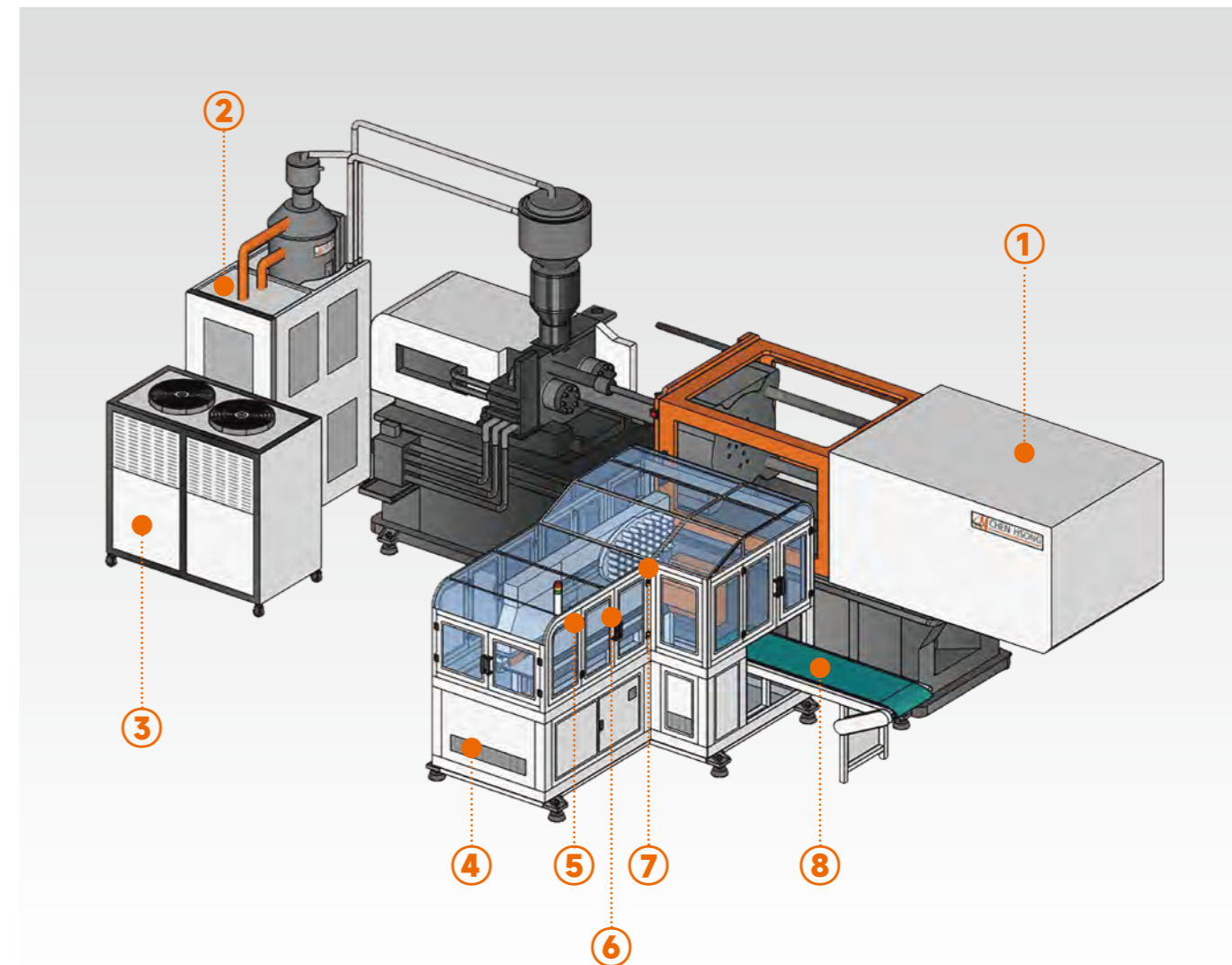

### Automation System Configuration

Project	No.	Item	Model
Integrated Automated Solution: Dual-Station PET Production with Side-Robot Unloading	①	Injection Molding Machine	JM480-PET/S2
	②	("ALL-in-one") compact dryer	CHD-300L/200H
	③	Chiller	CH-LF40A
	④	Electric System	Non-Std
	⑤	Cooling	Out Mold Cooling
	⑥	Robot	2-Axis Robot/Integrated Water Cooling
	⑦	Mold	96
	⑧	Conveyor System	Non-Std

# iChen™ Smart Factory

One-Click Smart Factory

Turnkey Solution

## 10L Pail with IML (In-Mold Labeling)



**Injection Molding Machine:** SPEED 568

**Cavities:** 1

**Cycle Time:** 15 seconds (full IML automation included)

**Weight:** 400g

**Material:** PP

**Capacity:** 10L

**Side-Entry IML Process Flow:**

1. Injection Molding
2. Part Extraction & Label Placement via Horizontal 2-Axis/3-Axis Robot
3. Finished Product Stacking
4. Discharge via Conveyor

**Products:**

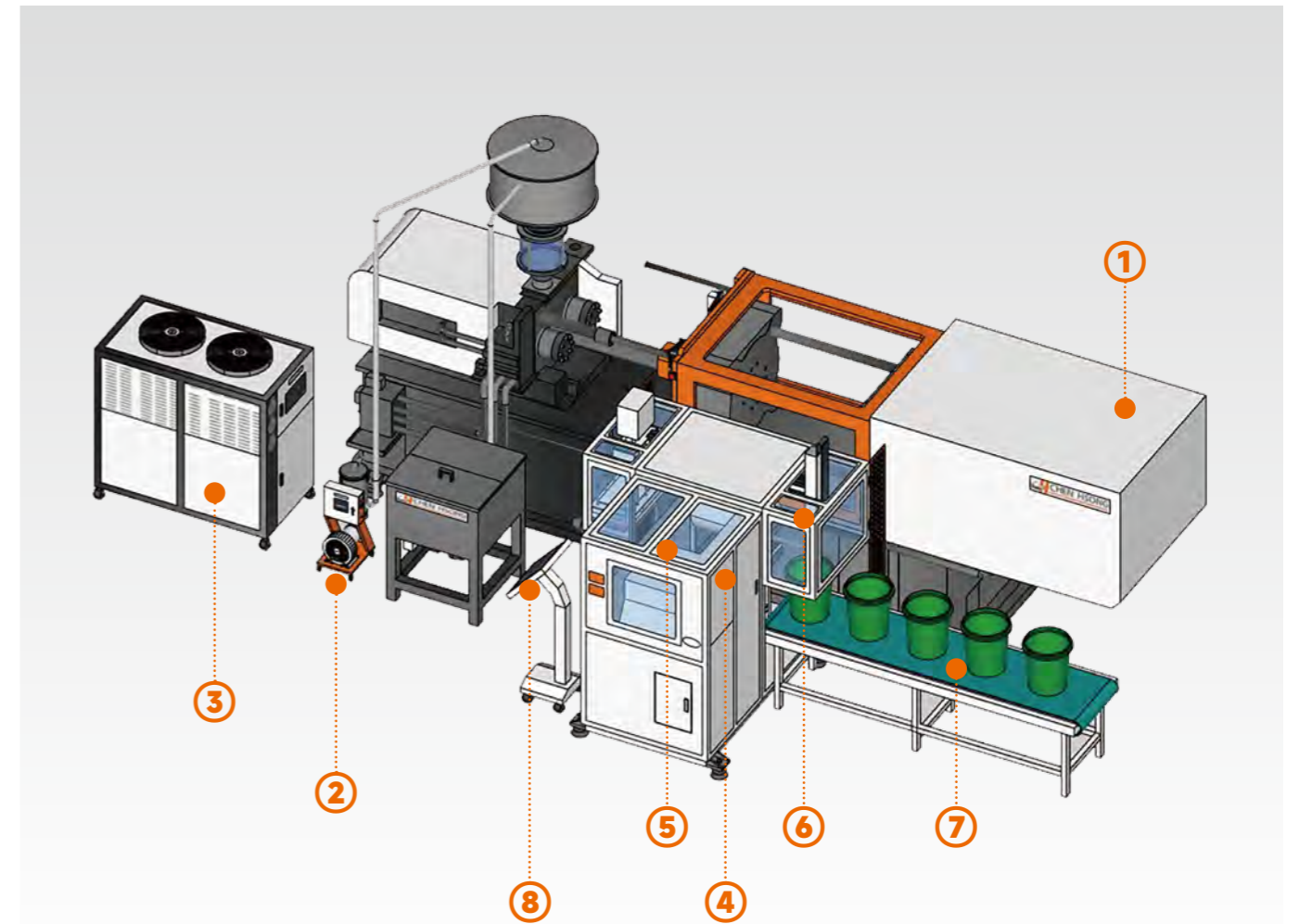

### Automation System Configuration

Project	No.	Item	Model
10L Pail with IML (In-Mold Labeling)	①	Injection Molding Machine	SPEED568
	②	Hopper Loader	CHAL-3HP
	③	Chiller	CH-LF15A
	④	Twin-Robot System	2-Axis Robot
	⑤	Label Magazine	Store with Label (Non-Std)
	⑥	Custom Fixture	Pick & Label
	⑦	Conveyor System	Non-Std
	⑧	Screen	10"

## Automated Packaging Solution for Food Containers



**Injection Molding Machine:** SUPER PACK430

**Cavities:** 6

**Material:** PP

**Capacity:** 1000mL

**Cycle Time:** 5 seconds

**Packaging Process Flow:**

1. Injection Molding
2. Part Extraction
3. Product Stacking
4. Repositioning & Transfer
5. Bagging & Sealing
6. Cartoning

**Products:**

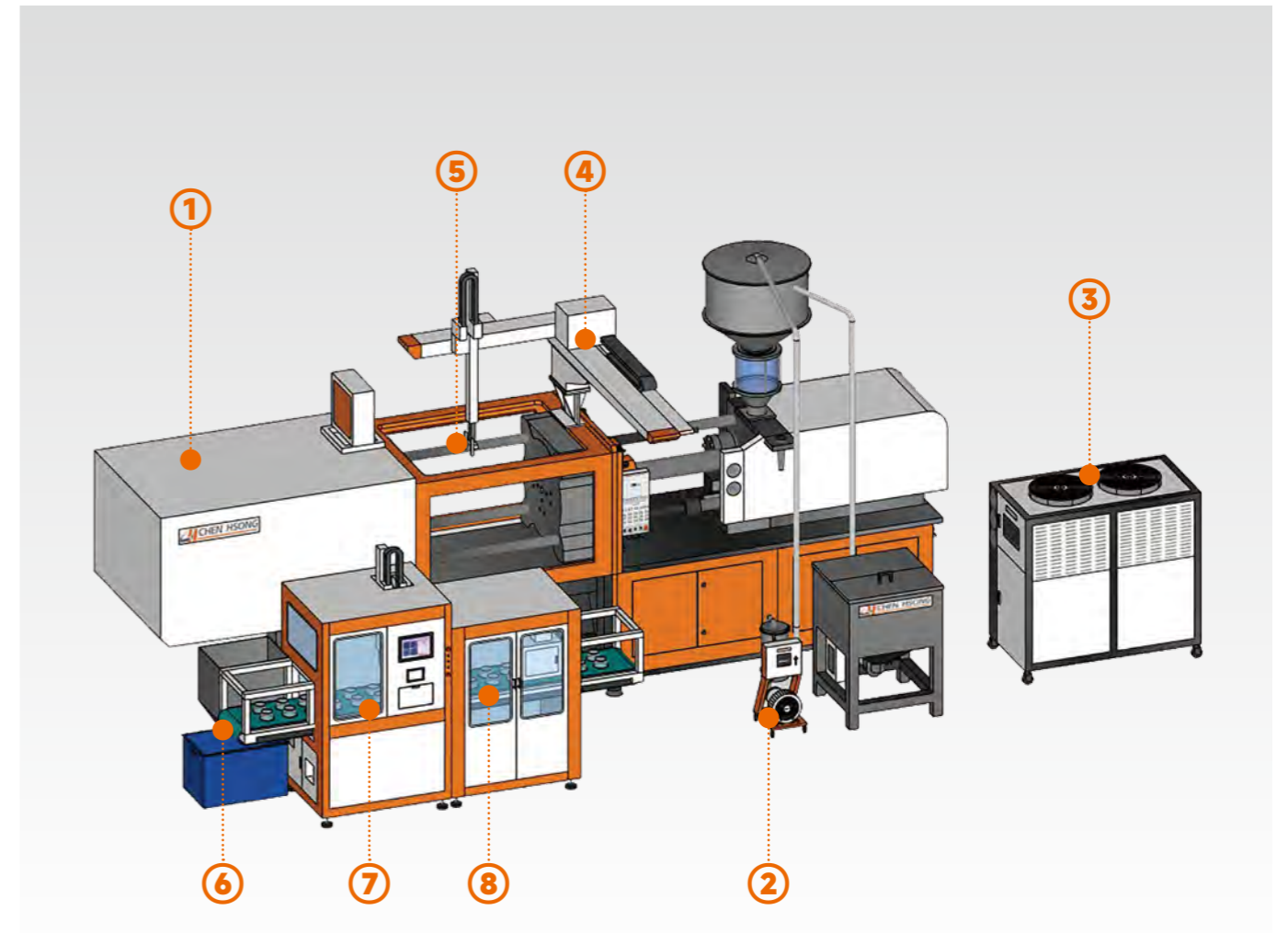

### Automation System Configuration

Project	No.	Item	Model
Automated Packaging Solution for Food Containers	①	Injection Molding Machine	SUPER PACK430
	②	Hopper Loader	CHAL-3HP
	③	Chiller	CH-LF20A
	④	Robot	3-Axis Robot
	⑤	Mold	Non-Std
	⑥	Conveyor System	Non-Std
	⑦	Control System	Non-Std
	⑧	Packaging System	Non-Std

## Integrated Automation with Top-Entry Unloading for Produce Crates



**Injection Molding Machine:** JM488-MK6.6/A

**Cavities:** 1

**Material:** PP

**Weight:** 2000g

**Size:** 489x348x278mm

**Cycle Time:** 20 seconds

**Process Flow (Top-Entry):**

1. Injection Molding
2. Part Extraction by 3-Axis Robot
3. Label Placement/Marking by Horizontal 2-Axis Robot
4. Conveyor Transfer

**Products:**

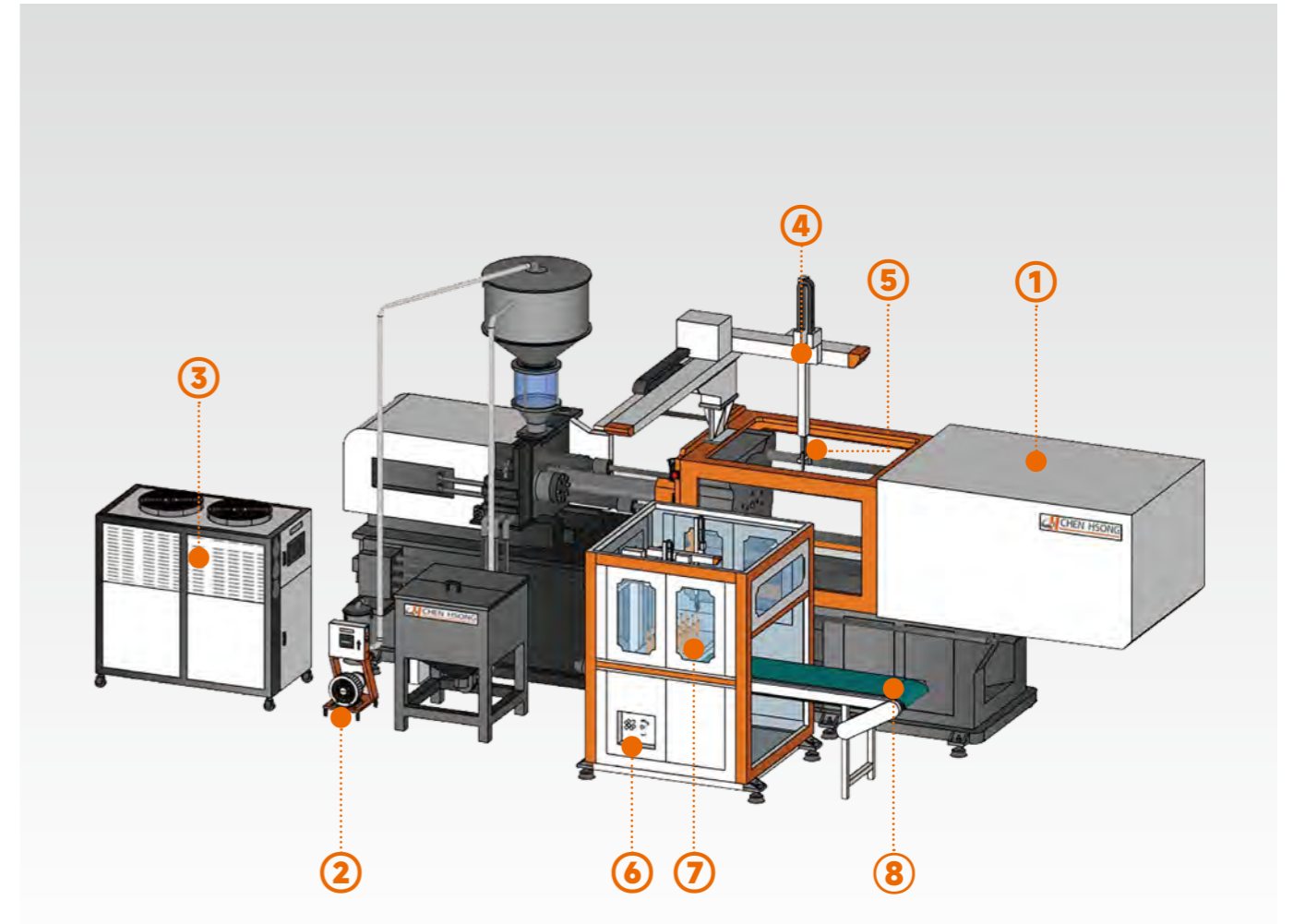

### Automation System Configuration

Project	No.	Item	Model
Integrated Automation with Top-Entry Unloading for Produce Crates	①	Injection Molding Machine	JM488-MK6.6/A
	②	Hopper Loader	CHAL-3HP
	③	Chiller	CH-LF20A
	④	Robot	3-Axis Robot/Pick
	⑤	Mold	Non-Std
	⑥	Control System	Non-Std
	⑦	Label Magazine	3-Axis Robot/Issue Label
	⑧	Conveyor System	Non-Std

## Seamless Integration of Intelligent Peripheral Equipment

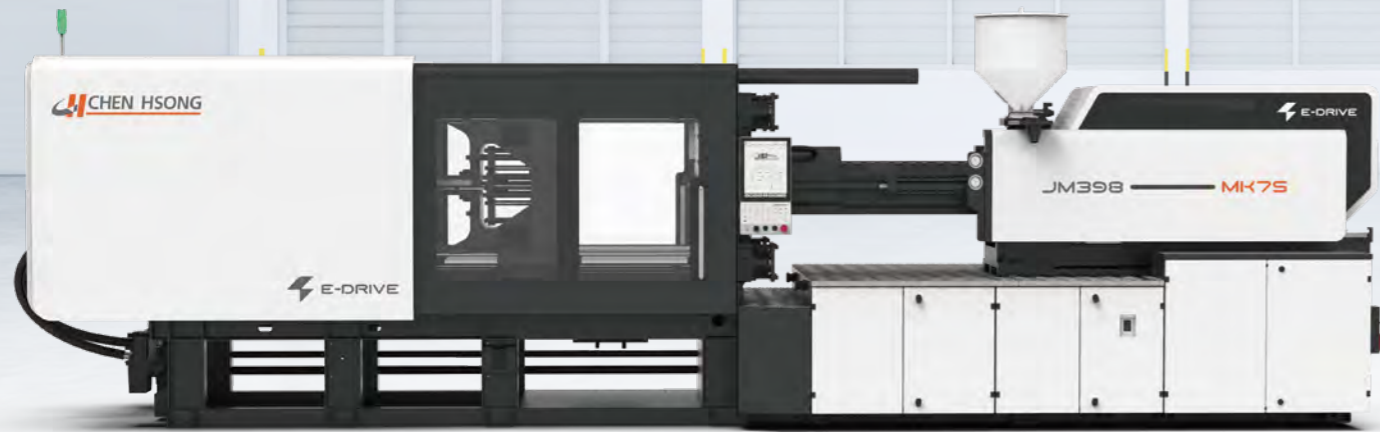

### Beyond the Machine, Empowering Your Entire Plant Champion One-Stop Injection Molding Ecosystem Solution

At CHEN HSONG, we understand that true efficiency stems from the seamless collaboration of your entire production system. That's why we offer far more than just a high-performance injection molding machine — we deliver a **complete plant-wide solution, from core to auxiliary, from individual units to integrated workflow.**

With CHEN HSONG injection molding machines as the **powerful heart** of your operation, we precision-match a full range of **elite support equipment** — including material loaders, dryers, mold temperature controllers, chillers, robots, and central conveying systems. Each auxiliary unit is not merely an add-on, but a carefully selected component based on your specific product and process requirements, ensuring that your entire production line operates like finely meshed gears — **seamlessly interlocked and highly synchronized.**

Choosing CHEN HSONG means you gain a **perfectly matched, stable, and maximized-efficiency** injection molding production system. We free you from the complexities of equipment selection and coordination, allowing you to focus on products and markets — truly delivering a **"One-Stop Turnkey Solution: Efficient from Day One."**

#### 1 Industrial Chiller Series



#### 2 Mold-Temperature Controller Series



#### 3 Granulator & Recycling Series



#### 4 Drying & Dehumidifying Series



#### 5 Mixing Series



#### 6 Feeding & Conveying Series



#### 7 Part-Removal Robot Series



#### 8 Hydraulic Mold-Change Clamps



#### 9 Auxiliary Accessories Series



Other  
Accessories